



E-MU AUDITY VOICES - GENERAL DESCRIPTION

5 DECEMBER 1979

THE E-MU AUDITY VOICE CARDS ARE DESIGNED TO BE COMPLETELY COMPUTER CONTROLLED SYNTHESIZER VOICES OF GOOD QUALITY AND MODERATE COMPLEXITY. THEY CAN BE INTERFACED TO ANY COMPUTER VIA "MEMORY-LIKE" INTERFACE, OR INTERFACED VIA AN E-MU SUPPLIED Z-80 MICROPROCESSOR BASED COMPUTER.

THE CARDS ARE PHYSICALLY DESIGNED TO FIT IN A RACK-MOUNTABLE CARD CAGE LESS THAN 21 INCHES HIGH AND 16 INCHES DEEP. EACH CARD HAS TWO IDENTICAL BUT SEPARATE OUTPUTS.

EACH CARD CONTAINS 2 VOLTAGE CONTROLLED OSCILLATORS WITH SAWTOOTH, VOLTAGE CONTROLLED WIDTH PULSE, AND TRIANGLE WAVEFORMS, A VOLTAGE CONTROLLED LOWPASS FILTER, A VOLTAGE CONTROLLED HIGHPASS FILTER, A VOLTAGE CONTROLLED AMPLIFIER, A PROGRAMMABLE RESONANT (PARAMETRIC) FILTER, A LOW FREQUENCY OSCILLATOR, A NOISE SOURCE, FOUR ADSR TYPE TRANSIENT GENERATORS, AND NUMEROUS CONTROLLABLE PATCH SWITCHES AND ATTENUATORS. A TOTAL OF 58 8 BIT WORDS CONTROL THE CARD.

THE ATTACHED DIAGRAM SHOWS THE BASIC PATCH POSSIBILITIES.

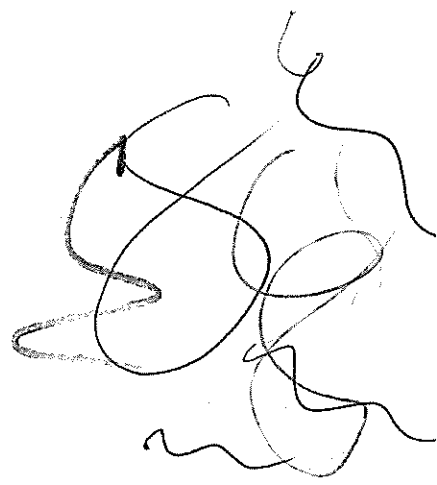

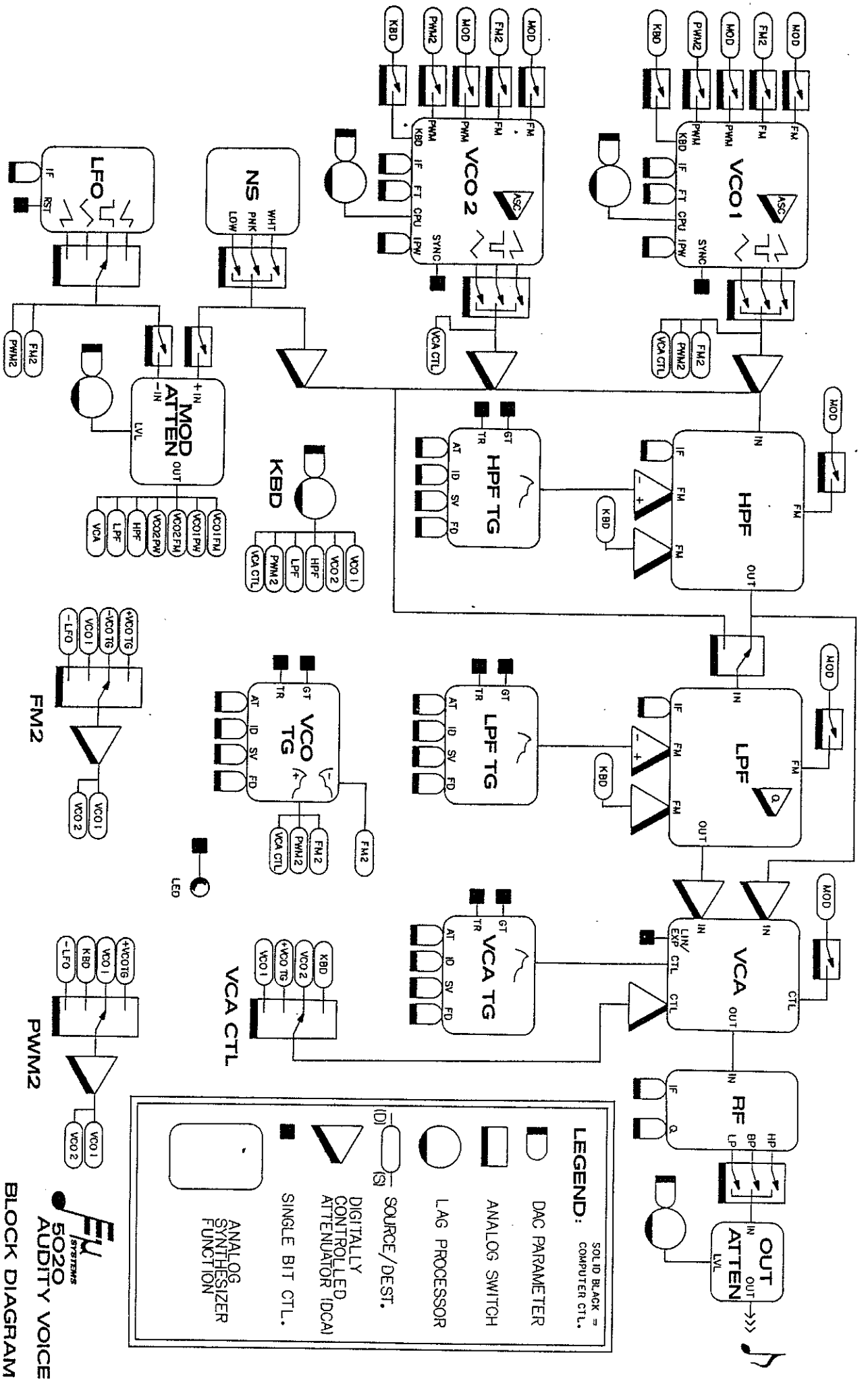

5020 SYSTEMS
 AUDIITY VOICE
 BLOCK DIAGRAM



E-MU AUDITY VOICE CARD - PARAMETER DEFINITIONS

14 JANUARY 1980

I. GENERAL DESCRIPTION

THE INFORMATION GIVEN IN THIS DOCUMENT DESCRIBES THE ADDRESSES AND FUNCTIONS OF THE DIGITAL CONTROL OVER THE E-MU AUDITY VOICE CARDS. IT IS ASSUMED THAT THE READER IS FAMILIAR WITH THE VOICE CARD BLOCK DIAGRAM AND SYNTHESIZER TERMINOLOGY.

ADDRESSES ARE GIVEN IN VALUES FROM 00-3F HEXADECIMAL. A GIVEN CARD WILL HAVE A BASE OFFSET ADDED TO THIS ADDRESS CORRESPONDING TO THE CARD NUMBER.

ALL PARAMETERS ARE EIGHT BIT WORDS. UNUSED BITS ARE INDICATED IN DESCRIPTIONS AND WILL BE IGNORED BY THE VOICE CARD, THOUGH FAITHFULLY RETAINED IN THE VOICE CARD MEMORY. SIMILARLY UNUSED PARAMETER LOCATIONS WITHIN THE CARD ADDRESS SPACE WILL NOT BE USED BY THE VOICE CARD BUT RETAINED IN ITS MEMORY. IT IS RECOMMENDED THAT UNUSED PARAMETERS AND BITS BE KEPT AT ZERO.

PARAMETERS ARE UPDATED ON AN ASYNCHRONOUS REFRESH CYCLE OF APPROXIMATELY 2.5 MILLISECONDS.

II. LIST OF CONTROLLABLE PARAMETERS

THE FOLLOWING IS A LIST OF CONTROLLABLE PARAMETERS FOR THE VOICE CARD. FOR QUICK ADDRESS REFERENCE, SEE THE REFERENCE TABLE AT THE END OF THIS DOCUMENT.

VCO (CONTROLLABLE FOR BOTH VCO 1 AND VCO 2):

INITIAL FREQUENCY
FINE TUNE
AUTOMATIC SENSITIVITY CONTROL
INITIAL PULSE WIDTH
MODULATION SOURCES & SYNC
WAVESHAPE
ATTENUATION
AUXILIARY CPU CONTROL
AUXILIARY CPU LAG TIME

AUXILIARY VCO SECTION (COMMON TO VCO 1 AND VCO 2):

KEYBOARD CONTROL VOLTAGE
KEYBOARD PORTAMENTO TIME
VCO TRANSIENT GENERATOR GATE & TRIGGER
VCO TRANSIENT GENERATOR ATTACK TIME
VCO TRANSIENT GENERATOR INITIAL DECAY TIME
VCO TRANSIENT GENERATOR SUSTAIN VOLTAGE
VCO TRANSIENT GENERATOR FINAL DECAY TIME
"FM2" BUS SIGNAL SOURCE
"FM2" BUS SIGNAL LEVEL
"PWM2" BUS SIGNAL SOURCE
"PWM2" BUS SIGNAL LEVEL

NOISE SOURCE:

SPECTRUM (WHITE-PINK-LOW FILTERED)
ATTENUATION INTO VCF SECTION

LOW FREQUENCY OSCILLATOR:

INITIAL FREQUENCY
WAVESHAPE
RESET (SYNC)

MODULATION BUS:

NOISE ON/OFF
LFO ON/OFF
LEVEL
LAG TIME ON LEVEL CHANGES

HIGHPASS FILTER:

INITIAL FREQUENCY
KEYBOARD TRACKING AMOUNT
TRANSIENT GENERATOR ATTACK TIME
TRANSIENT GENERATOR INITIAL DECAY TIME
TRANSIENT GENERATOR SUSTAIN VOLTAGE
TRANSIENT GENERATOR FINAL DECAY TIME
TRANSIENT GENERATOR GATE AND TRIGGER
TRANSIENT GENERATOR FREQUENCY CONTROL AMOUNT
FREQUENCY MODULATION BUS ON/OFF
OUTPUT LEVEL TO VCA

LOWPASS FILTER:

INITIAL FREQUENCY
KEYBOARD TRACKING AMOUNT
TRANSIENT GENERATOR ATTACK TIME
TRANSIENT GENERATOR INITIAL DECAY TIME
TRANSIENT GENERATOR SUSTAIN VOLTAGE
TRANSIENT GENERATOR FINAL DECAY TIME
TRANSIENT GENERATOR GATE AND TRIGGER
TRANSIENT GENERATOR FREQUENCY CONTROL AMOUNT
FREQUENCY MODULATION BUS ON/OFF
SIGNAL SOURCE (SERIES=HPF OR PARALLEL=OSCILLATORS & NOISE)
RESONANCE (Q) AMOUNT
OUTPUT LEVEL TO VCA

VOLTAGE CONTROLLED AMPLIFIER:

TRANSIENT GENERATOR ATTACK TIME
TRANSIENT GENERATOR INITIAL DECAY TIME
TRANSIENT GENERATOR SUSTAIN VOLTAGE
TRANSIENT GENERATOR FINAL DECAY TIME
TRANSIENT GENERATOR GATE AND TRIGGER
EXPONENTIAL OR LINEAR CONTROL BY TRANSIENT GENERATOR
AMPLITUDE MODULATION BUS ON/OFF
AUXILIARY AMPLITUDE MODULATION SOURCE SELECTION
AUXILIARY AMPLITUDE MODULATION LEVEL

RESONANT FILTER:

INITIAL FREQUENCY
RESONANCE (Q)
OUTPUT MIXTURE (FROM HP-BP-LP)

OUTPUT ATTENUATOR:

ATTENUATION
LAG TIME ON ATTENUATION CHANGES

MISCELLANEOUS:

TEST LED OFF/ON
EXTERNAL KEYBOARD CV INPUT (NOT IMPLEMENTED ON FIRST BOARD RUN)

III. LIST OF PARAMETERS WITH ADDRESSES AND DETAILED FUNCTIONAL DESCRIPTIONS

THE FOLLOWING LIST IN ORDER OF ADDRESS LOCATION GIVES THE COMPLETE FUNCTIONAL DESCRIPTION OF EACH PARAMETER WORD OR BIT. FOR INDEXING FROM PARAMETER NAME, SEE THE PARAMETER REFERENCE TABLE AT THE END OF THIS DOCUMENT.

ADDRESS 00 - KEYBOARD CONTROL VOLTAGE:

THIS PRECISE SIGNAL IS PASSED THROUGH THE PORTAMENTO CIRCUIT AND USED AS THE SYSTEM KEYBOARD CONTROL VOLTAGE. WHEN PATCHED TO THIS SIGNAL, THE VCO'S WILL TRACK AT PRECISELY 1 OCTAVE FOR EVERY 24 STEPS (18 HEXIDECIMAL), THUS GIVING 2 STEPS PER SEMITONE. OSCILLATORS AND FILTERS WILL ONLY BE MOVED UP IN PITCH BY THIS SIGNAL, HENCE THEIR INITIAL FREQUENCIES SHOULD BE SET TO THE POINT DESIRED WITH ZERO (LOWEST) KEYBOARD CV.

ADDRESS 01 - VCO 2 PULSE WIDTH:

THIS SIGNAL DETERMINES THE PULSE WIDTH OF THE VCO2 PULSE WAVEFORM. 80 HEX (128 DECIMAL) IS TRIMMED TO GIVE A PRECISE SQUARE WAVE. VARIATIONS FROM THIS 50% DUTY CYCLE ARE AT 0.42%/STEP, I. E. 50.42% DUTY CYCLE RESULTS FROM A VALUE OF 81 HEXIDECIMAL.

ADDRESS 02 - VCO1 INITIAL FREQUENCY:

THIS SIGNAL DETERMINES THE VCO1 FREQUENCY WHEN NO OTHER MODULATION IS GIVEN. IT IS TRIMMED TO GIVE 880 HZ WHEN GIVEN A VALUE OF 90 HEXIDECIMAL, AND VARIES THE FREQUENCY AT 24 STEPS (18 HEX) PER OCTAVE, GIVING QUARTER TONE RESOLUTION. NOTE THAT THE KEYBOARD VARIES THE FREQUENCY UP FROM THIS VALUE.

ADDRESS 03 - VCO2 FINE TUNE:

THIS PARAMETER, NOMINALLY SET TO 80 HEX, GIVES VERY PRECISE CONTROL OVER THE VCO FREQUENCY. IT SHOULD BE USED BY THE CPU IN CONJUNCTION WITH THE EACH CARD'S FREQUENCY SENSE OUTPUT TO PRECISELY TRIM THE FREQUENCY OF THE VCO TO 880 HZ WITH THE INITIAL FREQUENCY PARAMETER SET TO 90 HEX AND NO MODULATION. IT VARIES THE VCO FREQUENCY AT 1/128 SEMITONE/STEP, AND CAN BE USED TO "DE-TUNE" VCO'S.

ADDRESS 04 - OUTPUT ATTENUATION:

THIS PARAMETER DETERMINES THE OUTPUT ATTENUATION LEVEL OF THE FINAL STAGE. IT SHOULD BE SET IN NORMAL USE TO AS LOW A VALUE (MINIMAL ATTENUATION) AS POSSIBLE FOR FULL "ON" CHANNELS, AND USED TO FADE OTHERS. THE EFFECT OF THE CONTROL IS LAGGED BY THE "OUTPUT ATTENUATION LAG TIME" PARAMETER TO ALLOW DYNAMIC FADES. THE ATTENUATION IS AT APPROXIMATELY 1/3 DB/STEP, WITH ZERO BEING NO ATTENUATION.

ADDRESS 05 - HIGHPASS FILTER INITIAL FREQUENCY:

THIS PARAMETER DETERMINES THE HIGHPASS FILTER CUTOFF FREQUENCY WHEN NO MODULATION IS PRESENT. AT AN 78 HEX VALUE IT IS TRIMMED TO A 440 HZ VALUE, WITH VARIATION FROM THIS POINT AT 24 STEPS (18 HEX) PER OCTAVE, I. E. QUARTER TONES.

ADDRESS 06 - LOWPASS FILTER INITIAL FREQUENCY:

SAME AS ADDRESS 05 BUT FOR THE LOWPASS FILTER CUTOFF FREQUENCY.

ADDRESS 07 - VCO 2 INITIAL FREQUENCY:

SAME AS ADDRESS 02 BUT FOR OSCILLATOR 2.

ADDRESS 08 - VCO 1 INITIAL PULSE WIDTH:

SAME AS ADDRESS 01 BUT FOR OSCILLATOR 1.

ADDRESS 09 - VCO 2 AUXILIARY FREQUENCY CONTROL:

THIS PARAMETER IS USED TO INCREASE THE FREQUENCY OF VCO 2 AT A RATE OF 1 OCTAVE PER 24 STEPS (18 HEX), WITH A PROGRAMMABLE LAG TIME (ADDRESS 23). WHEN UNUSED IT SHOULD BE SET TO ZERO.

ADDRESS 0A - VCO 1 AUXILIARY FREQUENCY CONTROL:

SAME AS ADDRESS 09 BUT FOR OSCILLATOR 1.

ADDRESS 0B - VCO 1 FINE TUNE:

SAME AS ADDRESS 03 BUT FOR OSCILLATOR 1.

ADDRESS 0C - MODULATION BUS ATTENUATION AMOUNT:
THIS PARAMETER DETERMINES THE ATTENUATION (0=FULL LEVEL) ON THE MODULATION BUS.
IT'S SENSITIVITY IS APPROXIMATELY 48 STEPS (30 HEX) PER DECADE ATTENUATION.

ADDRESS 0D - RESONANT FILTER INITIAL FREQUENCY:
THIS PARAMETER DETERMINES THE RESONANT FREQUENCY OF THE RESONANT FILTER. IT IS
SET FOR A 880 HZ VALUE AT A SETTING OF 80 HEX, AND VARIES AT 24 STEPS (18 HEX)
PER OCTAVE FROM THIS POINT.

ADDRESS 0E - LOW FREQUENCY OSCILLATOR INITIAL FREQUENCY:
THIS PARAMETER DETERMINES THE LOW FREQUENCY OSCILLATOR FREQUENCY. IT IS SET
FOR 20 HZ AT A 78 HEX VALUE, AND VARIES AT APPROXIMATELY 24 STEPS (18 HEX) PER
OCTAVE. NOTE: THE PARAMETER IS INVERTED - HIGHER VALUES RESULT IN LOWER
FREQUENCIES.

ADDRESS 0F - RESONANT FILTER RESONANCE (Q) LEVEL:
THIS PARAMETER DETERMINES THE RESONANCE (Q) OF THE RESONANT FILTER. AT ZERO,
THE FILTER HAS NO RESONANCE (Q=0.5), AND THE Q NOMINALLY DOUBLES FOR EACH 32
STEPS (20 HEX).

ADDRESS 10 - HIGHPASS FILTER TRANSIENT GENERATOR INITIAL DECAY TIME:
THIS PARAMETER DETERMINES THE HIGHPASS FILTER TRANSIENT GENERATOR'S TIME
CONSTANT FOR INITIAL DECAY. A VALUE OF 80 HEX GIVES A 1 SECOND VALUE
FOR A 80% APPROACH, AND THE SENSITIVITY IS APPROXIMATELY 48 STEPS PER DECADE
(30 HEX) ABOUT THIS VALUE.

ADDRESS 11 - HIGHPASS FILTER TRANSIENT GENERATOR FINAL DECAY TIME:
SAME AS ADDRESS 10 FOR THE FINAL DECAY TIME.

ADDRESS 12 - HIGHPASS FILTER TRANSIENT GENERATOR SUSTAIN VOLTAGE:
THIS PARAMETER DETERMINES THE INITIAL DECAY APPROACH VOLTAGE FOR THE HIGHPASS
FILTER TRANSIENT GENERATOR. IT VARIES FROM ZERO FOR ZERO VOLTS AT A RATE OF
24 STEPS (18 HEX) PER VOLT. THE ATTACK VOLTAGE FOR A TRANSIENT GENERATOR IS
10 VOLTS, SO A VALUE OF 240=FO HEX GIVES AN A-R TYPE TRANSIENT.

ADDRESS 13 - HIGHPASS FILTER TRANSIENT GENERATOR ATTACK TIME:
THIS PARAMETER DETERMINES THE ATTACK TIME FOR THE HIGHPASS FILTER TRANSIENT
GENERATOR. A VALUE OF 80H GIVES A 1 SECOND ATTACK TIME, AND THE SENSITIVITY
IS APPROXIMATELY 48 STEPS (30 HEX) PER DECADE ABOUT THIS POINT.

ADDRESS 14 - LOWPASS FILTER TRANSIENT GENERATOR ATTACK TIME:
SAME AS ADDRESS 13 BUT FOR THE LOWPASS FILTER TRANSIENT GENERATOR.

ADDRESS 15 - LOWPASS FILTER TRANSIENT GENERATOR SUSTAIN VOLTAGE:
SAME AS ADDRESS 12 BUT FOR THE LOWPASS FILTER TRANSIENT GENERATOR.

ADDRESS 16 - LOWPASS FILTER TRANSIENT GENERATOR INITIAL DECAY TIME:
SAME AS ADDRESS 10 BUT FOR THE LOWPASS FILTER TRANSIENT GENERATOR.

ADDRESS 17 - LOWPASS FILTER TRANSIENT GENERATOR FINAL DECAY TIME:
SAME AS ADDRESS 11 BUT FOR THE LOWPASS FILTER TRANSIENT GENERATOR.

ADDRESS 18 - VCO TRANSIENT GENERATOR INITIAL DECAY TIME:
SAME AS ADDRESS 10 BUT FOR THE VCO TRANSIENT GENERATOR.

ADDRESS 19 - VCO TRANSIENT GENERATOR FINAL DECAY TIME:
SAME AS ADDRESS 11 BUT FOR THE VCO TRANSIENT GENERATOR.

ADDRESS 1A - VCO TRANSIENT GENERATOR SUSTAIN VOLTAGE:
SAME AS ADDRESS 12 BUT FOR THE VCO TRANSIENT GENERATOR.

ADDRESS 1B - VCO TRANSIENT GENERATOR ATTACK TIME:
SAME AS ADDRESS 13 BUT FOR THE VCO TRANSIENT GENERATOR.

ADDRESS 1C - VCA TRANSIENT GENERATOR ATTACK TIME:
SAME AS ADDRESS 13 BUT FOR THE VCA TRANSIENT GENERATOR.

ADDRESS 1D - VCA TRANSIENT GENERATOR SUSTAIN VOLTAGE:
SAME AS ADDRESS 12 BUT FOR THE VCA TRANSIENT GENERATOR.

ADDRESS 1E - VCA TRANSIENT GENERATOR INITIAL DECAY TIME:
SAME AS ADDRESS 10 BUT FOR THE VCA TRANSIENT GENERATOR.

ADDRESS 1F - VCA TRANSIENT GENERATOR FINAL DECAY TIME:
SAME AS ADDRESS 11 BUT FOR THE VCA TRANSIENT GENERATOR.

ADDRESS 20 - FILTER CONTROL WORD:

BITS 4-7: UNUSED

BIT 3: EXTERNAL KEYBOARD CV ON/OFF - NOT IMPLEMENTED - LEAVE ZERO.

BIT 2: MODULATION BUS TO HIGHPASS FILTER FREQUENCY - A "1" VALUE CAUSES THE MOD
BUS TO MODULATE THE HIGHPASS FILTER FREQUENCY.

BIT 1: MODULATION BUS TO LOWPASS FILTER FREQUENCY - A "1" CAUSES FREQUENCY
MODULATION BY THE MODULATION BUS.

BIT 0: LOWPASS FILTER SIGNAL SELECTION - A "0" VALUE CAUSES THE FILTERS TO ACT
IN SERIES, I. E. THE LOWPASS FILTER OBTAINS ITS SIGNAL FROM THE HIGHPASS
FILTER OUTPUT. A "1" VALUE IS FOR PARALLEL OPERATION, THE LOWPASS
FILTER'S SIGNAL INPUT IS THE SAME AS THE HIGHPASS FILTER'S, BEING THE
SUM OF THE OSCILLATOR AND NOISE ATTENUATOR OUTPUTS.

ADDRESS 21 - HIGHPASS FILTER KEYBOARD TRACKING AMOUNT:

THIS PARAMETER DETERMINES THE EXTENT TO WHICH THE HIGHPASS FILTER TRACKS THE
KEYBOARD CONTROL VOLTAGE. A ZERO VALUE RESULTS IN NO TRACKING, AND THE AMOUNT
INCREASES LINEARLY WITH 80 HEX BEING 1 VOLT PER OCTAVE TRACKING.

ADDRESS 22 - LOWPASS FILTER KEYBOARD TRACKING AMOUNT:

SAME AS ADDRESS 21 BUT FOR THE LOWPASS FILTER.

ADDRESS 23 - VCO AUXILIARY CONTROL LAG TIMES:

BITS 4-7: CONTROL THE LAG RATE ON VCO 1 AUXILIARY CONTROL. A "0" GIVES NO LAG, AND THE LAG INCREASES IN LOGARITHMIC STEPS FROM 4 MSEC TO 4 SECS FOR VALUES 2 THROUGH 15. THIS PARAMETER MUST BE LEFT AT ZERO WHEN NOT IN USE.

BITS 0-3: ARE THE SAME AS BITS 4-7 FOR VCO 2 AUXILIARY CONTROL. AGAIN, THIS PARAMETER MUST BE ZERO WHEN NOT IN USE.

ADDRESS 24 - RESONANT FILTER/OUTPUT CONTROL WORD:

BITS 4-7: CONTROL THE LAG TIME ON THE OUTPUT ATTENUATION PARAMETER. A "0" GIVES NO LAG, AND THE LAG INCREASES IN LOGARITHMIC STEPS FROM 4 MSEC TO 4 SEC FOR VALUES FROM 2 THROUGH 15.

BIT 3: RESONANT FILTER HIGHPASS OUTPUT ON - A "1" ALLOWS THE RESONANT FILTER HIGHPASS OUTPUT TO BE MIXED INTO THE FINAL OUTPUT ATTENUATOR.

BIT 2: RESONANT FILTER BANDPASS OUTPUT ON - A "1" TURNS ON THE BANDPASS OUTPUT.

BIT 1: RESONANT FILTER LOWPASS OUTPUT ON - A "1" TURNS ON THE LOWPASS OUTPUT.

BIT 0: TEST LED OFF - A "0" TURNS THE TEST LED ON THE BOARD ON, A "1" OFF.

ADDRESS 25 - LOW FREQUENCY OSCILLATOR - NOISE SOURCE - MODULATION BUS CONTROL:

BIT 7: LFO RESET (SYNC) - A "1" TO "0" TRANSITION ON THIS BIT FORCES THE LFO SAWTOOTH TO DISCHARGE, THE PULSE TO RISE, AND THE TRIANGLE WAVEFORM TO JUMP TO THE MAXIMUM POINT IN THE WAVEFORM.

BITS 5-6: THESE BITS SELECT THE LFO WAVEFORM:

0 (00)=INVERTED SAWTOOTH (JUMP TO +10 VOLTS, RAMP TO ZERO).

1 (01)=SQUARE WAVEFORM (ZERO TO +10 VOLTS)

2 (10)=TRIANGLE WAVEFORM (+5 TO -5 VOLTS)

3 (11)=SAWTOOTH WAVEFORM (RAMP TO +10 VOLTS, JUMP BACK TO ZERO)

BIT 4: A "1" CONNECTS THE LFO OUTPUT INTO THE MODULATION BUS ATTENUATOR.

BIT 3: A "1" SUMS WHITE NOISE INTO THE NOISE SOURCE OUTPUT.

BIT 2: A "1" SUMS PINK NOISE (-3DB/OCTAVE FILTER) INTO THE NOISE SOURCE OUTPUT.

BIT 1: A "1" SUMS LOW FILTERED NOISE (-6DB/OCTAVE FILTER) INTO NOISE OUTPUT.

BIT 0: A "1" SUMS THE NOISE SOURCE INTO THE MODULATION BUS ATTENUATOR.

ADDRESS 26 - MODULATION LAG TIME:

BITS 4-7: UNUSED

BITS 0-3: CONTROL THE LAG TIME ON CHANGES IN THE MODULATION BUS ATTENUATION (ADDRESS 0C). A "0" GIVES NO LAG, AND THE LAG INCREASES IN LOGARITHMIC STEPS FROM 4 MSEC TO 4 SEC FOR VALUES FROM 2 THROUGH 15.

ADDRESS 27 - GATES AND TRIGGERS:

- BIT 7: VCA TRANSIENT GENERATOR TRIGGER - A "0" TO "1" TRANSITION MUST ACCOMPANY ANY SUCH TRANSITION ON THE GATE BIT FOR CORRECT FUNCTION. IF ADDITIONAL ATTACK PHASES ARE DESIRED (RETRIGGERING) THIS BIT MAY BE BROUGHT TO "0" WITH NO EFFECT. WHEN A NEW "0" TO "1" TRANSITION OCCURS AND THE TRANSIENT GENERATOR IS IN INITIAL DECAY PHASE, A NEW ATTACK PHASE TO +10 VOLTS AT THE ATTACK TIME WILL BEGIN.
- BIT 6: VCA TRANSIENT GENERATOR GATE - A "1" CAUSES THE VCA TRANSIENT GENERATOR TO FIRE (MUST BE ACCOMPANIED BY A "1" ON THE TRIGGER FOR CORRECT FUNCTION). WHEN THE GATE IS PRESENT, THE TRANSIENT GENERATOR WILL ATTACK TO +10 VOLTS AT THE ATTACK TIME, THEN DECAY TO THE SUSTAIN VOLTAGE AT THE INITIAL DECAY TIME. WHENEVER THE GATE IS BROUGHT TO "0", THE TRANSIENT GENERATOR WILL DECAY TO ZERO VOLTS AT THE FINAL DECAY TIME.
- BIT 5: LOWPASS FILTER TRANSIENT GENERATOR TRIGGER.
- BIT 4: LOWPASS FILTER TRANSIENT GENERATOR GATE
- BIT 3: HIGHPASS FILTER TRANSIENT GENERATOR TRIGGER.
- BIT 2: HIGHPASS FILTER TRANSIENT GENERATOR GATE.
- BIT 1: VCO TRANSIENT GENERATOR TRIGGER.
- BIT 0: VCO TRANSIENT GENERATOR GATE.

ADDRESS 28 - HIGHPASS FILTER TRANSIENT GENERATOR FREQUENCY MODULATION LEVEL: THIS PARAMETER DETERMINES THE SIGN AND AMOUNT OF MODULATION ON THE HIGHPASS FILTER CUTOFF FREQUENCY BY THE HIGHPASS FILTER TRANSIENT GENERATOR. THE SENSITIVITY IS LINEAR WITH 80 HEXIDECIMAL BEING NO MODULATION, FF HEX BEING UNITY GAIN POSITIVE MODULATION, AND ZERO BEING UNITY GAIN NEGATIVE MODULATION.

ADDRESS 29 - LOWPASS FILTER TRANSIENT GENERATOR FREQUENCY MODULATION LEVEL: SAME AS ADDRESS 28 BUT FOR THE LOWPASS FILTER.

ADDRESS 2A - VCA AUXILIARY AMPLITUDE MODULATION LEVEL
THIS PARAMETER DETERMINES THE LEVEL OF THE SELECTED AUXILIARY AMPLITUDE MODULATION SIGNAL (ADDRESS 2B). THE RESPONSE IS LINEAR WITH ZERO BEING OFF AND FF HEX BEING UNITY GAIN.

ADDRESS 2B - VCA CONTROL WORD

BITS 4-7: NOT USED

- BIT 3: A "0" ALLOWS THE VCA TRANSIENT GENERATOR TO VARY THE SIGNAL AMPLITUDE IN A LINEAR FASHION. A "1" CHANGES THAT RELATIONSHIP TO EXPONENTIAL.
- BIT 2: A "1" ALLOWS THE MODULATION BUS TO AMPLITUDE MODULATE THE SIGNAL. THIS EFFECT IS MULTIPLIED WITH THE TRANSIENT GENERATOR AND IS EXPONENTIAL IN EFFECT, THUS A CONSTANT DB MODULATION LEVEL WILL RESULT THROUGHOUT THE TRANSIENT GENERATOR CYCLE.
- BIT 0-1: VCA AUXILIARY MODULATION SIGNAL SELECTION (SEE ADDRESS 2A)
- 0 (00)=KEYBOARD CONTROL VOLTAGE
 - 1 (01)=VCO 2 OUTPUT
 - 2 (10)=VCO TRANSIENT GENERATOR
 - 3 (11)=VCO 1 OUTPUT

ADDRESS 2C - HIGHPASS FILTER OUTPUT LEVEL

THIS PARAMETER DETERMINES THE AMOUNT OF HIGHPASS FILTER OUTPUT ROUTED TO THE VCA. ZERO IS OFF, AND THE VARIATION IS LINEAR WITH FF HEX BEING UNITY GAIN.

ADDRESS 2D - LOWPASS FILTER OUTPUT LEVEL

SAME AS ADDRESS 2C BUT FOR THE LOWPASS FILTER

ADDRESS 2E - LOWPASS FILTER RESONANCE (Q)

THIS PARAMETER DETERMINES THE RESONANCE OF THE LOWPASS FILTER. ZERO IS NO RESONANCE ($Q=1/2$). THE RESONANCE INCREASES TO OSCILLATION AT FO HEX. THE OSCILLATION LEVEL VARIES SLIGHTLY WITH FREQUENCY, SO VALUES BELOW EO HEX SHOULD BE USED AS A MAXIMUM VALUE TO GUARANTEE LACK OF OSCILLATION.

ADDRESS 2F - PORTAMENTO TIME

BITS 4-7: NOT USED

BITS 0-3: CONTROL THE PORTAMENTO TIME FOR THE KEYBOARD CONTROL VOLTAGE. A "0" GIVES NO PORTAMENTO, AND THE TIME CONSTANT INCREASES LOGARITHMICALLY FROM 4 MSEC TO 4 SECS FOR VALUES FROM 2 TO 15.

ADDRESS 30 - VCO 1 MODULATION CONTROL WORD:

BIT 7: NOT USED

BIT 6: NOT USED

BIT 5: A "1" ALLOWS THE "PWM2" BUS TO MODULATE THE PULSE WIDTH.

BIT 4: A "1" ALLOWS THE MODULATION BUS TO MODULATE THE PULSE WIDTH.

BIT 3: A "1" CAUSES THE VCO TO SYNC TO THE OTHER VCO. WHEN THE OTHER VCO DISCHARGES ITS SAWTOOTH, THIS VCO IS ALSO FORCED TO DISCHARGE.

BIT 2: A "1" ALLOWS THE "FM2" BUS TO MODULATE THE FREQUENCY.

BIT 1: A "1" ALLOWS THE MODULATION BUS TO MODULATE THE FREQUENCY.

BIT 0: A "1" CAUSES THE VCO TO TRACK THE KEYBOARD CONTROL VOLTAGE.

ADDRESS 31 - VCO 1 AUTOMATIC SENSITIVITY CONTROL:

THIS PARAMETER SHOULD NOMINALLY BE SET TO 80 HEXIDECIMAL. IF THE COMPUTER DETERMINES BY MEANS OF THE FREQUENCY SENSE OUTPUT FROM THE CARD THAT THE VCO IS NOT TRACKING AT PRECISELY 1 OCTAVE/24 STEPS FROM THE FREQUENCY CONTROLS, THIS PARAMETER CAN BE VARIED. A LARGER VALUE WILL RESULT IN LESS SENSITIVITY TO THE FREQUENCY PARAMETERS, I. E. HIGHER PITCH AT FREQUENCIES BELOW 880 HZ.

ADDRESS 32 - VCO 2 MODULATION CONTROL WORD:

SAME AS ADDRESS 30 BUT FOR VCO 2.

ADDRESS 33 - VCO 2 AUTOMATIC SENSITIVITY CONTROL:

SAME AS ADDRESS 31 BUT FOR VCO 2.

ADDRESS 34 - VCO WAVEFORM SELECTION:

BIT 7: NOT USED

BIT 6: A "1" SUMS VCO 2 SAWTOOTH INTO THE VCO 2 OUTPUT.

BIT 5: A "1" SUMS VCO 2 PULSE INTO THE VCO 2 OUTPUT.

BIT 4: A "1" SUMS VCO 2 TRIANGLE INTO THE VCO 2 OUTPUT.

BIT 3: NOT USED

BIT 2: A "1" SUMS VCO 1 SAWTOOTH INTO THE VCO 1 OUTPUT.

BIT 1: A "1" SUMS VCO 1 PULSE INTO THE VCO 1 OUTPUT.

BIT 0: A "1" SUMS VCO 1 TRIANGLE INTO THE VCO 1 OUTPUT.

ADDRESS 35 - VCO 1 OUTPUT ATTENUATOR:

DETERMINES THE LEVEL AT WHICH VCO 1 IS PATCHED TO THE FILTERS. A VALUE OF FF HEXIDECIMAL IS OFF, AND 00 HEXIDECIMAL IS FULL LEVEL. THE RELATIONSHIP IS NON-LINEAR, AND EQUATIONS AND GRAPHS OF THE RESPONSE ARE GIVEN AT THE END OF THIS SECTION.

ADDRESS 36 - VCO 2 OUTPUT ATTENUATOR:

SAME AS ADDRESS 35 BUT FOR VCO 2.

ADDRESS 37 - NOISE SOURCE OUTPUT ATTENUATOR:

SAME AS ADDRESS 35 BUT FOR THE NOISE SOURCE LEVEL INTO THE FILTERS.

ADDRESS 38 - "PWM2" BUS LEVEL:

THIS PARAMETER DETERMINES THE LEVEL OF THE SELECTED "PWM2" SIGNAL (ADDRESS 3A) ONTO THE "PWM2" BUS. THE RESPONSE IS LINEAR WITH ZERO BEING OFF AND FF HEX BEING FULL LEVEL.

ADDRESS 39 - "FM2" BUS LEVEL:

THIS PARAMETER DETERMINES THE LEVEL OF THE SELECTED "FM2" SIGNAL (ADDRESS 3A) ONTO THE "FM2" BUS. THE RESPONSE IS LINEAR WITH ZERO BEING OFF AND FF HEX BEING FULL LEVEL.

ADDRESS 3A - "FM2" AND "PWM2" SIGNAL SELECTION:

BITS 4-7: NOT USED

BITS 2-3: SELECT THE "FM2" BUS SIGNAL FOR ATTENUATION (ADDRESS 39)

0 (00)=+VCO TRANSIENT GENERATOR

1 (01)=-VCO TRANSIENT GENERATOR

2 (10)=VCO 1 OUTPUT

3 (11)=INVERTED LFO (MODULATES FREQUENCY DOWNWARD)

BITS 0-1: SELECTS THE "PWM2" BUS SIGNAL FOR ATTENUATION (ADDRESS 38)

0 (00)=VCO TRANSIENT GENERATOR

1 (01)=VCO 1 OUTPUT

2 (10)=KEYBOARD CONTROL VOLTAGE

3 (11)=INVERTED LFO

ADDRESS 3B - NOT USED

LEAVE ZERO IF POSSIBLE

ADDRESS 3C - NOT USED

LEAVE ZERO IF POSSIBLE

ADDRESS 3D - NOT USED
LEAVE ZERO IF POSSIBLE

ADDRESS 3E - NOT USED
LEAVE ZERO IF POSSIBLE

ADDRESS 3F - NOT USED
LEAVE ZERO IF POSSIBLE

SIGNAL ATTENUATOR RESPONSE

THE SIGNAL ATTENUATORS (ADDRESSES 35,36,37) HAVE A NON-LINEAR RESPONSE ALLOWING PRECISE SIGNAL LEVEL CONTROL OVER A WIDE DYNAMIC RANGE. MATHEMATICALLY, FOR A PARAMETER VALUE N WHERE N VARIES FROM ZERO TO 255, THE ATTENUATION IN DB IS GIVEN BY THE EQUATION:

$$\text{ATTENUATION (DB)} = 20 \text{ LOG } [(255-N)/(11N+256)]$$

GRAPHICALLY, THE ATTENUATION VERSUS PARAMETER VALUE PLOT IS:

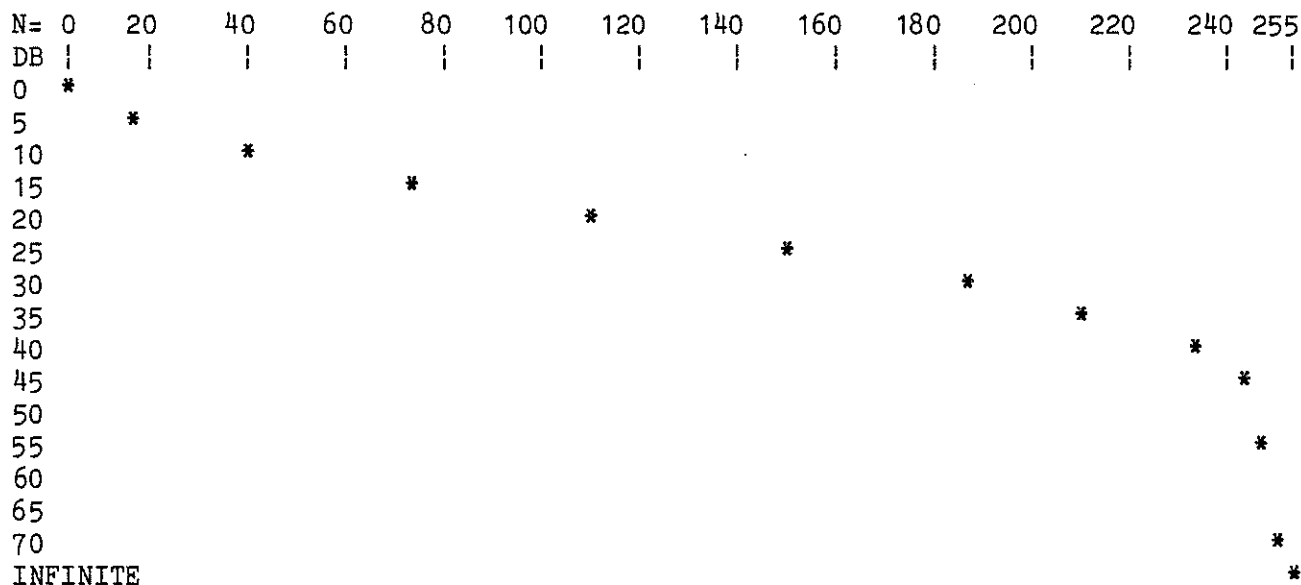



E-MU AUDIITY VOICE CARD - SIGNAL DEFINITIONS AND SPECIFICATIONS 14 JANUARY 1980

I. GENERAL DESCRIPTION

THIS DOCUMENT DESCRIBES INPUT AND OUTPUT SIGNALS FROM THE E-MU AUDIITY VOICE CARDS WITH MEMORY-LIKE DIGITAL INTERFACE. SIGNAL LEVELS, IMPEDANCES, AND TIMINGS ARE DISCUSSED.

POWER SUPPLY REQUIREMENTS ARE GIVEN.

DIGITAL SIGNALS, THEIR FUNCTIONS, LOADINGS, AND TIMINGS ARE DISCUSSED.

ANALOG OUTPUT SPECIFICATIONS ARE GIVEN.

II. POWER REQUIREMENTS

ONLY THREE POWER SUPPLIES ARE REQUIRED:

+5 VOLTS - USED FOR DIGITAL CIRCUITRY. NEITHER GREAT STABILITY NOR LOW RIPPLE AND NOISE ARE REQUIRED. WE RECOMMEND A SWITCHING SUPPLY IF POSSIBLE.

VOLTAGE: +5 VDC +/- 5%

CURRENT: 6 AMPERES AT OPERATING TEMPERATURE

LINE AND LOAD REGULATION: 1% OVER RATED RANGE

RIPPLE AND NOISE: 50 MILLIVOLT PEAK TO PEAK MAXIMUM

TEMPERATURE STABILITY: WITHIN 1% OVER OPERATING TEMPERATURE

+20 VOLTS - USED FOR CMOS AND ANALOG CIRCUITRY. POST REGULATED ON EACH CIRCUIT BOARD. NEITHER GREAT STABILITY NOR LOW RIPPLE AND NOISE ARE REQUIRED. WE RECOMMEND A SWITCHING SUPPLY IF POSSIBLE.

VOLTAGE: +20 VDC +/- 5%

CURRENT: 14 AMPERES AT OPERATING TEMPERATURE

LINE AND LOAD REGULATION: 1% OVER RATED RANGE

RIPPLE AND NOISE: 100 MILLIVOLTS PEAK TO PEAK MAXIMUM

TEMPERATURE STABILITY: WITHIN 1% OVER OPERATING TEMPERATURE

-20 VOLTS - USED FOR ANALOG CIRCUITRY. POST REGULATED ON EACH CIRCUIT BOARD. NEITHER GREAT STABILITY NOR LOW RIPPLE AND NOISE ARE REQUIRED. WE RECOMMEND A SWITCHING SUPPLY IF POSSIBLE.

VOLTAGE: -20 VDC +/- 5%

CURRENT: 10 AMPERES AT OPERATING TEMPERATURE

LINE AND LOAD REGULATION: 1% OVER RATED RANGE

RIPPLE AND NOISE: 100 MILLIVOLTS PEAK TO PEAK MAXIMUM

TEMPERATURE STABILITY: WITHIN 1% OVER OPERATING TEMPERATURE

THE POWER SUPPLIES SHOULD BE MOUNTED AS FAR FROM THE VOICE CARD CAGE AS PRACTICAL TO MINIMIZE TEMPERATURE CHANGES AT THE VOICE CARDS. A SEPARATE ENCLOSURE WOULD BE DESIRABLE. THE SPECIFICATIONS ARE TO BE MEASURED AT THE VOICE CARD CAGE CONNECTIONS; REMOTE SENSING MAY BE NECESSARY.

II. ANALOG SIGNAL OUTPUTS

EACH VOICE CARD HAS TWO EQUIVALENT OUTPUTS. THEY ARE TYPICAL OF MODERN SYNTHESIZERS SUCH AS ARP AND E-MU< BEING A 1.0K OHM 1/4 WATT RESISTOR DRIVEN BY AN OP-AMP WITH +/- 15 VOLT SUPPLIES.

OUTPUT IMPEDANCE 1.0K OHM, SINGLE ENDED. 2 INDEPENDENT CHANNELS CARRYING THE SAME SIGNAL ON EACH BOARD.

NOMINAL OUTPUT LEVEL: 10V PEAK TO PEAK FOR TYPICAL LEVEL OUTPUT SIGNAL.
OUTPUT LEVEL AT CLIPPING: 25V PEAK TO PEAK.
MAXIMUM OUTPUT CURRENT: +/- 5 MILLIAMPS TOTAL CURRENT BOTH OUTPUTS
MAXIMUM DC OFFSET WITH MAXIMUM ATTENUATION AT OUTPUT ATTENUATOR: 50 MILLIVOLTS.
MAXIMUM DC OFFSET AT ANY OUTPUT ATTENUATION: 500 MILLIVOLTS.

THE OUTPUT ATTENUATOR ON EACH CHANNEL MAY BE USED TO PROGRAM THE OUTPUT LEVEL TO ANY VALUE BELOW THE MAXIMUMS GIVEN ABOVE WITH LITTLE SIGNAL/NOISE PENALTY.

WE RECOMMEND THE OUTPUTS BE CARRIED FROM THE BOARDS BY SHIELDED CABLES. IF A BALANCED OUTPUT IS REQUIRED, MATCHING TRANSFORMERS ARE RECOMMENDED.

III. DIGITAL SIGNALS AND COMPUTER INTERFACE

THERE ARE THREE VARIETIES OF DIGITAL SIGNALS TO AND FROM THE DIGITAL INTERFACE. A DATA BUS 8 BITS WIDE CARRIES DATA TO AND FROM THE CARDS. AN ADDRESS BUS 12 BITS WIDE SELECTS THE CARD AND WORD TO BE ADDRESSED. CONTROL LINES DETERMINE THE FUNCTION TO BE PERFORMED.

ALL SIGNALS ARE TTL COMPATIBLE. THE LOADING ON ANY INPUT IS TYPICALLY ONE TTL UNIT LOAD. ANY OUTPUT IS CAPABLE OF DRIVING AT LEAST TWO TTL UNIT LOADS.

ALL SIGNALS SHOULD BE CONNECTED USING TWISTED PAIRS WITH GROUND.

TWO FUNCTIONS CAN BE PERFORMED - READ AND WRITE. THE CYCLES WILL BE DESCRIBED SEPARATELY. REFER TO TIMING DIAGRAMS AT THE END OF THIS SECTION.

A READ CYCLE BEGINS WITH A FALLING EDGE ON THE SYNTHRQ (USER REQUEST) LINE WHILE THE READ LINE IS LOW. THE ADDRESS LINES SHOULD BE THE VALID ADDRESS OF THE WORD TO BE READ AT THIS TIME, AND THE WRITE LINE SHOULD BE HIGH. THE DATA BUS SHOULD BE IN A HIGH IMPEDANCE STATE READY TO ACCEPT OUTPUT DATA. THE ADDRESS BUS SHOULD REMAIN VALID, THE READ LINE LOW, AND THE WRITE LINE HIGH THROUGHOUT THE READ CYCLE.

A FEW NANoseconds AFTER THE SYNTHRQ LINE FALLS, THE INTERFACE WILL ENABLE ITS DATA BUS DRIVERS. WITHIN 1.2 MICROSECONDS AFTER THE FALLING EDGE OF SYNTHRQ, THE VALID DATA WILL BE PRESENT ON THE DATA BUS. THE DATA WILL REMAIN VALID UNTIL THE SYNTHRQ LINE GOES HIGH. THIS MUST BE NO LONGER THAN 30 MICROSECONDS AFTER THE FALLING EDGE OF SYNTHRQ. SYNTHRQ MUST REMAIN HIGH FOR NO LESS THAN 200 NANoseconds TO COMPLETE THE CYCLE. THE DATA BUS WILL RETURN TO A HIGH IMPEDANCE STATE WITHIN 200 NANoseconds OF THE RISING EDGE OF SYNTHRQ.

A WRITE CYCLE IS SIMILAR TO A READ CYCLE EXCEPT THAT IT BEGINS WITH THE WRITE LINE LOW AND THE READ LINE HIGH. ALSO AT THE FALLING EDGE OF SYNTHRQ, THE ADDRESS BUS SHOULD BE THE VALID ADDRESS OF THE WORD TO BE WRITTEN AND THE DATA BUS SHOULD BE THE VALID DATA. THE WRITE LINE SHOULD REMAIN LOW, THE READ LINE HIGH, AND THE DATA AND ADDRESS BUSES VALID THROUGHOUT THE WRITE CYCLE.

THE WRITE OPERATION WILL BE COMPLETED WITHIN 1.2 MICROSECONDS OF THE FALLING EDGE OF SYNTHRQ. AT THIS TIME, OR UP TO 30 MICROSECONDS AFTER THE FALLING EDGE OF SYNTHRQ, SYNTHRQ SHOULD BE BROUGHT HIGH. THE ADDRESS AND DATA BUS SHOULD REMAIN VALID, THE READ LINE HIGH, THE WRITE LINE LOW, AND THE SYNTHRQ LINE HIGH FOR AT LEAST 200 NANoseconds AFTER THE RISING EDGE OF SYNTHRQ TO COMPLETE THE WRITE CYCLE.

ALL SIGNALS WILL BE WIRE-WRAPPED ON THE CARD CAGE BY THE USER.

THE USER SIGNALS ARE ALL PREFIXED BY "USER". THEY ARE:

USER ADDRESS BUS (UA0-UA11) 12 LINES.

USER DATA BUS (UDB0-UDB7) 8 LINES.

-USER READ REQUEST

-USER WRITE REQUEST

-USER REQUEST (SYNTHRQ)

READ CYCLE:

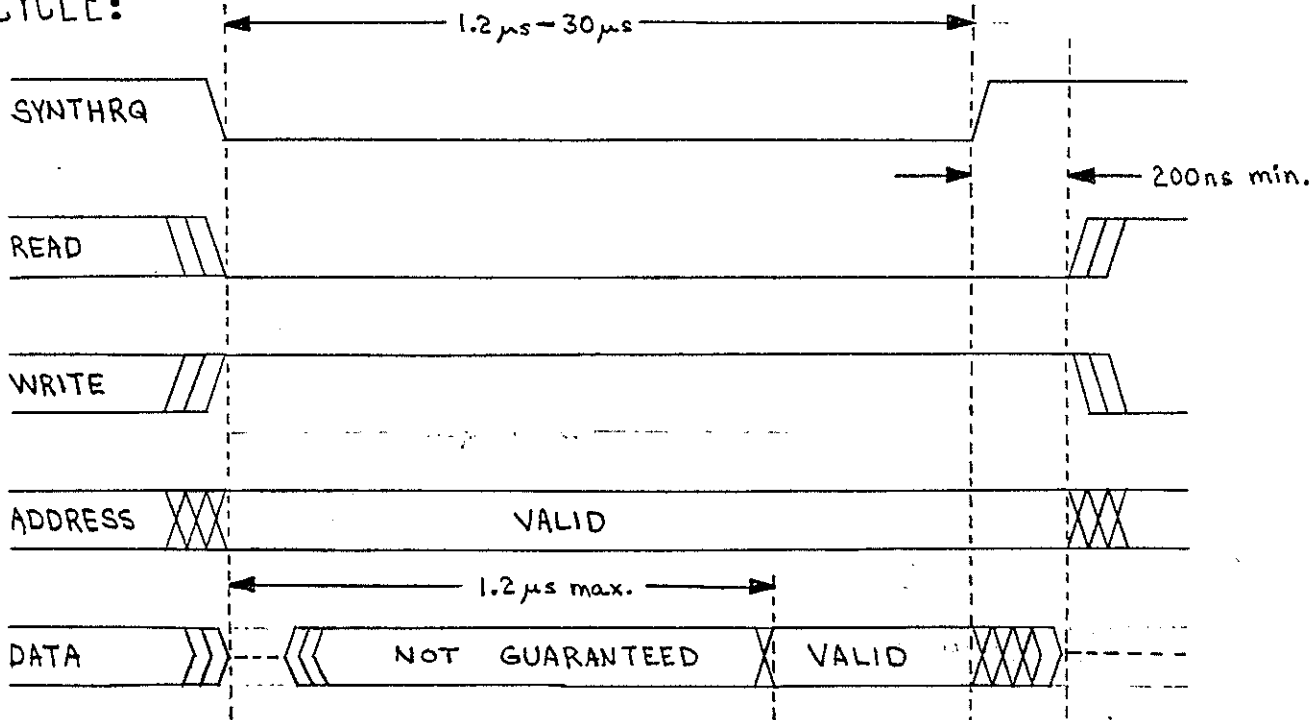

WRITE CYCLE:

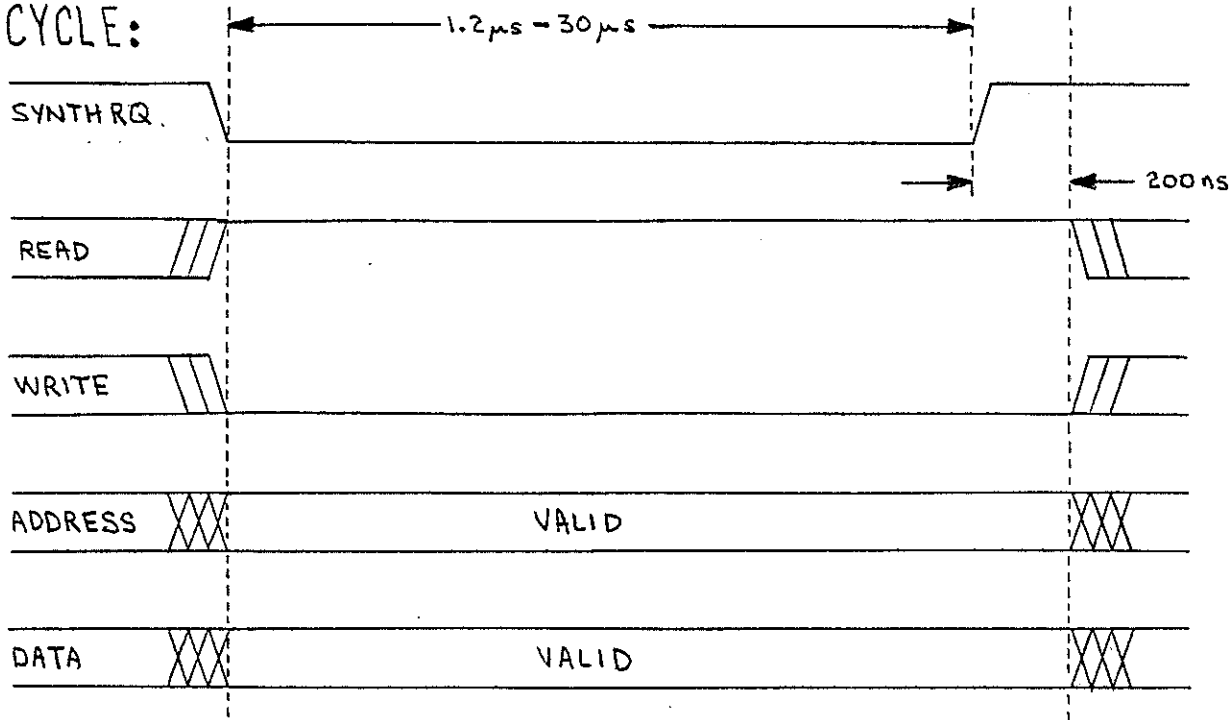

E μ SYSTEMS	5 DEC 79
DWN:	CK:
DOC N $^{\circ}$	
TIMING DIAGRAM - MEMORY-LIKE INTERFACE	



E-MU AUDITY VOICE BOARD - AUTOTUNE INSTRUCTIONS . 14 JANUARY 1980

I. GENERAL DESCRIPTION

This document describes the E-mu AUDITY voice board provisions for the autotune function, and the general guidelines the user should follow to implement the autotune function.

The autotune function is ABSOLUTELY NECESSARY in any computer controlled synthesizer situation. The function should be available as a routine executed by the computer either automatically periodically throughout use, or called by the user as well as automatically after power-up.

II. THE AUTOTUNE FUNCTION

The autotune function performs two independent calibrations on each VCO in the system. These are the two most critical trims in the system, and adjust the VCO frequency and tracking.

The autotune performs these trims by first sensing actual VCO frequency and then adjusting parameters in the voice to make the voice respond correctly. This might be repeated if substantial corrections are necessary.

There are two parameters per VCO to be adjusted. The FINE TUNE parameter adjusts the initial frequency of the VCO to exactly 880 Hz. The ASC parameter (for automatic sensitivity control) adjusts the response of the keyboard to be precisely 24 (18 Hex) steps per octave.

The autotune procedure should be executed in steps:

First, the computer should force the VCO in question to produce a square waveform of what is expected to be 880 Hz. It is recommended this be accomplished by eliminating all FM and PWM, patching the keyboard to the VCO, setting the initial frequency to 30 Hex, the VCO CPU control to 0, and the keyboard with portamento off to 60 Hex. At least 5 msec should be allowed after this has been done to allow the refresh to bring the parameters to the desired levels.

Second, the computer should sense the VCO frequency. This is accomplished using the FREQUENCY SENSE outputs from the voice cards. These outputs are open-collector TTL compatible signals for maximum flexibility. The value will be high impedance when the VCO pulse is in the low state (initial pulse width is FF Hex), and results in a square wave when the VCO pulse output gives a square waveform. It is recommended that the falling edges be used for minimum jitter effects. A pull up is required on the outputs, which can be wire-AND tied.

Two methods suggest themselves. The computer can implement separate counting hardware for each FREQUENCY SENSE output. The time between a small number of falling edges is counted using a crystal clock, and the frequency computed from the count. Alternatively, all the FREQUENCY SENSE outputs can be wire-AND tied, and the computer can set all VCO's not to be counted such that their pulse waveforms never go high (No PWM and FF Hex initial pulse width is sufficient). Then the FREQUENCY SENSE bus can be implemented with a single counter for all VCO's. The latter approach requires less hardware, but will require more time to implement the AUTOTUNE function and requires all VCO's be disabled during autotune.

The frequency count should be accurate to 0.05% at least. The number of cycles required to be counted will be determined by the frequency of the crystal clock used. It is recommended that more than one cycle be used to average jitter effects.

Third, the error from 880 Hz to the actually detected frequency is computed as a number of 1/128 semitone intervals. The FINE TUNE parameter for the VCO in question is then changed by this number (an increase in value increases the frequency) to result in a VCO at 880 HZ +/- 1/128 semitone.

Fourth, the computer then changes the keyboard parameter down two octaves (with the values given, to 30 Hex), and a 5 msec wait is again required. This should bring the VCO frequency down to 220 Hz.

Fifth, the frequency is again measured, as above.

Sixth, the error from 220 Hz is computed in increments of 1/400 semitones, and the result added to ASC parameter for the VCO in question (an increase in value for this parameter will increase the frequency is if the frequency near 220 Hz.)

Seventh, the entire process is repeated if the errors found were large.

III. SOFTWARE IMPLEMENTATION

The frequency sensing can actually be done nearly entirely by software if sufficient time is allowed and the CPU is running in an interrupt-disabled state with a crystal controlled CPU clock. The number of CPU instructions executed is counted, and this is used to determine the frequency. The appended Z-80 assembly language listing illustrates this technique for the FINE TUNE correction only.

LOC OBJ CODE M STMT SOURCE STATEMENT

ASM 5.8

```

1
2
3
0000 DD2100F8 4 AUTOTN LD IX,VOICE0
0004 DDE5 5 PUSH IX
0006 D1 6 POP DE
0007 3E10 7 LD A,16 ; FILL 16 VOICES WITH NULL STUFF
0009 21AC00 R 8 SETUP LD HL,CALVC
000C 014000 9 LD BC,40H
000F EDB0 10 LDIR
0011 3D 11 DEC A
0012 20F5 12 JR NZ,SETUP
0014 CD6200 R 13 AUTOLP CALL TESTVC ; TEST IF VOICE PRESENT
0017 2038 14 JR NZ,NXTVC
0019 DD360880 15 LD (IX+VCO1PW),128
001D DD362400 16 LD (IX+LED),0 ; LED ON DURING TUNE
0021 CD7100 R 17 CALL WAIT ; WAIT FOR EFFECT
0024 CD7A00 R 18 CALL FREQ ; GET VALUE FOR VCO1 FREQ
0027 CD9E00 R 19 CALL TUNER
002A DD660B 20 LD H,(IX+VCO1FT)
002D 84 21 ADD A,H
002E DD770B 22 LD (IX+VCO1FT),A
0031 DD3608FF 23 LD (IX+VCO1PW),255
0035 DD360180 24 LD (IX+VCO2PW),128
0039 CD7100 R 25 CALL WAIT
003C CD7A00 R 26 CALL FREQ
003F CD9E00 R 27 CALL TUNER
0042 DD6603 28 LD H,(IX+VCO2FT)
0045 84 29 ADD A,H
0046 DD7703 30 LD (IX+VCO2FT),A
0049 DD3601FF 31 LD (IX+VCO2PW),255
004D DD362401 32 LD (IX+LED),1
0051 114000 33 NXTVC LD DE,40H
0054 DD19 34 ADD IX,DE
0056 DDE5 35 PUSH IX
0058 D1 36 POP DE
0059 2140FC 37 LD HL,VOICE0+17*40H
005C A7 38 AND A
005D ED52 39 SBC HL,DE
005F 20B3 40 JR NZ,AUTOLP
0061 C9 41 RET
42
0062 DD7E00 43 TESTVC LD A,(IX) ;
0065 2F 44 CPL

```

LOC	OBJ CODE	M	STMT	SOURCE	STATEMENT
0066	DD7700		45	LD	(IX),A
0069	DDBE00		46	CP	(IX)
006C	2F		47	CPL	
006D	DD7700		48	LD	(IX),A
0070	C9		49	RET	
			50		;
0071	212C01		51	WAIT LD	HL,SCANTM
0074	2B		52	SCANLP DEC	HL
0075	7C		53	LD	A,H
0076	B5		54	OR	L
0077	20FB		55	JR	NZ,SCANLP ; WAIT TILL VALUES IN EFFECT
0079	C9		56	RET	
			57		;
007A	F3		58	FREQ DI	; NO INTERRUPT DURING COUNT ROUTINES
007B	210000		59	LD	HL,0 ; HL COUNTS LOOPS
007E	067B		60	LD	B,123 ; COUNT 123 CYCLES
0080	DB09		61	LOOPHI IN	A,(9) ; WAIT TILL HIGH STATE
0082	E620		62	AND	MASK
0084	28FA		63	JR	Z,LOOPHI
0086	DB09		64	LOOPLO IN	A,(9) ; NOW FIND FALLING EDGE
0088	E620		65	AND	MASK
008A	20FA		66	JR	NZ,LOOPLO
008C	DB09		67	CLOW IN	A,(9) ; COUNT LOOPS WHILE LOW
008E	23		68	INC	HL
008F	E620		69	AND	MASK
0091	28F9		70	JR	Z,CLOW
0093	DB09		71	CHIGH IN	A,(9) ; NOW COUNT WHILE HIGH
0095	23		72	INC	HL
0096	E620		73	AND	MASK
0098	20F9		74	JR	NZ,CHIGH
009A	10F0		75	DJNZ	CLOW ; AND COUNT B CYCLES TOTAL
009C	FB		76	EI	; TOTAL TIME IS 8+3*B+72*HL CYCLES
009D	C9		77	RET	; 880 HZ WOULD BE 8717 COUNTS
			78		;
009E	110C22		79	TUNER LD	DE,8716
00A1	A7		80	AND	A
00A2	ED52		81	SBC	HL,DE
00A4	7D		82	LD	A,L
00A5	CB2C		83	SRA	H
00A7	1F		84	RRA	
00A8	CB2C		85	SRA	H
00AA	1F		86	RRA	; A IS HL/4
00AB	C9		87	RET	
			88		;



417 Broadway
Santa Cruz, CA 95060
(408) 429-9147

PARTS LIST - E-mu Systems SSM Chip Voice Demo Board

QTY	PART	MFR'S PART NUMBER
1	Circuit Board	Available from E-mu - \$50 by itself
1	Edge Conn.	TEKA TP5-W01-50 or any S-100 type.

The following parts are required for the on-board power supply. None are required if +/- 15V are supplied to the board externally. The user must supply fused 110VAC to the board's power connector.

1	Power Conn.	MOLEX 09-65-1031
1	Mating Conn.	MOLEX 09-50-3031 with 3 08-50-0106 pins
1	Transformer	SIGNAL TRANSFORMER ST 4-36
2	200uF 40V Cap	SPRAGUE 500D208G050FF7
4	1N4002 Diode	MOTOROLA
2	2N4923	MOTOROLA
2	Heatsinks	THERMALLOY 6073
2	Hdwe for above	2 ea. 4-40x1/2" screw, nut, lockwasher
1	741 opamp	NATIONAL LM741CN
1	723 regulator	NATIONAL LM723CN
1	2N3904	MOTOROLA
4	3.01K 1% Res	DALE RN55D
1	3.32K 1% Res	DALE RN55D
1	9.09K 1% Res	DALE RN55D
2	3.9 ohm Res	Any 1/4 watt 5%
1	200 ohm	"
1	470 pF Cap	SPRAGUE 5GA-T47

The following parts are required depending on filter option:

LOWPASS:

4	1000 pF Cap	SPRAGUE 5GA-D10
5	10K Res	Any 1/4 watt 5%

HIGHPASS:

4	2000 pF Cap	SPRAGUE 5GA-D20
---	-------------	-----------------

ALLPASS (Phase-shifter):

4	2000 pF Cap	SPRAGUE 5GA-D20
5	10K Res	Any 1/4 watt 5%

The remaining parts are required for stuffing the board as per schematics:

QTY	PART	MFR'S PART NUMBER
1	741 opamp	NATIONAL LM741CN
4	1458 d1 opamp	NATIONAL LM1458CN
4	d1 bifet opamp	TEXAS INSTRUMENTS TL082CP or NATIONAL LF353N
1	SSM2020 Custom IC, available from E-mu for \$7.50 ea.	
2	SSM2030 Custom IC, available from E-mu for \$10.00 ea.	
1	SSM2040 Custom IC, available from E-mu for \$10.00 ea.	
2	SSM2050 Custom IC, available from E-mu for \$7.50 ea.	
8	1N914 Diode	FAIRCHILD or any 1N914 or 1N4148
2	10K Trimmer	BECKMAN 91BR10K
2	20K Trimmer	SPECTROL 64Y203 (20 turn)
1	20K Trimmer	BECKMAN 91BR20K
4	100k Trimmer	BECKMAN 91BR100K
2	121 ohm 1% R	DALE RN55D
2	54.9K 1% Res	DALE RN55D
2	90.9K 1% Res	DALE RN55D
2	100K 1% Res	DALE RN55D
2	267K 1% Res	DALE RN55D
3	1.0K Tempco R	TEL LABS Q-81, available from E-mu for \$3.50 ea.
3	5 pF Cap	SPRAGUE 10TSV33
3	22 pF Cap	SPRAGUE 10TSQ22
4	100 pF Cap	SPRAGUE 10TST10
4	1000 pF Cap	SPRAGUE 5GAD10
2	1000 pF PolyS	MALLORY SXM110, available from E-mu for \$0.45 ea.
2	0.01 uF Cap	SPRAGUE TG-S10
14	0.1 uF Cap	SPRAGUE 3CZU104D8050C5
2	10 uF 35V Tant	SPRAGUE 196D106X0035PE4
4	200 ohm Res	All following are any 1/4 watt 5%
11	1.0K	
6	2.2K	
2	7.5K	
10	10K	
4	15K	
4	20K	
4	22K	
2	27K	
8	47K	
1	56K	
1	91K	
29	100K	
2	150K	
5	270K	
6	330K	
2	470K	
2	1.5M	
2	2.2M	
2	2.7M	
2	10M	

Except parts so specified above, E-mu will not sell listed parts separately. Add \$2.00 for handling on all orders for parts alone.

The following kit prices include handling charge:

E-mu Voice Evaluation Kit: Includes circuit board, the 6 SSM IC's, 3 Tempco resistors, and 2 Polystyrene caps. -- \$100.00 postpaid

E-mu Voice Kit (complete parts): Includes all parts listed above. If you have trouble obtainig parts, you should order this. -- \$250.00 postpaid

E-mu Voice (assembled and tested): Complete board, assembled & tested.
-- \$450 postpaid

CALIFORNIA RESIDENTS - ADD SALES TAX!

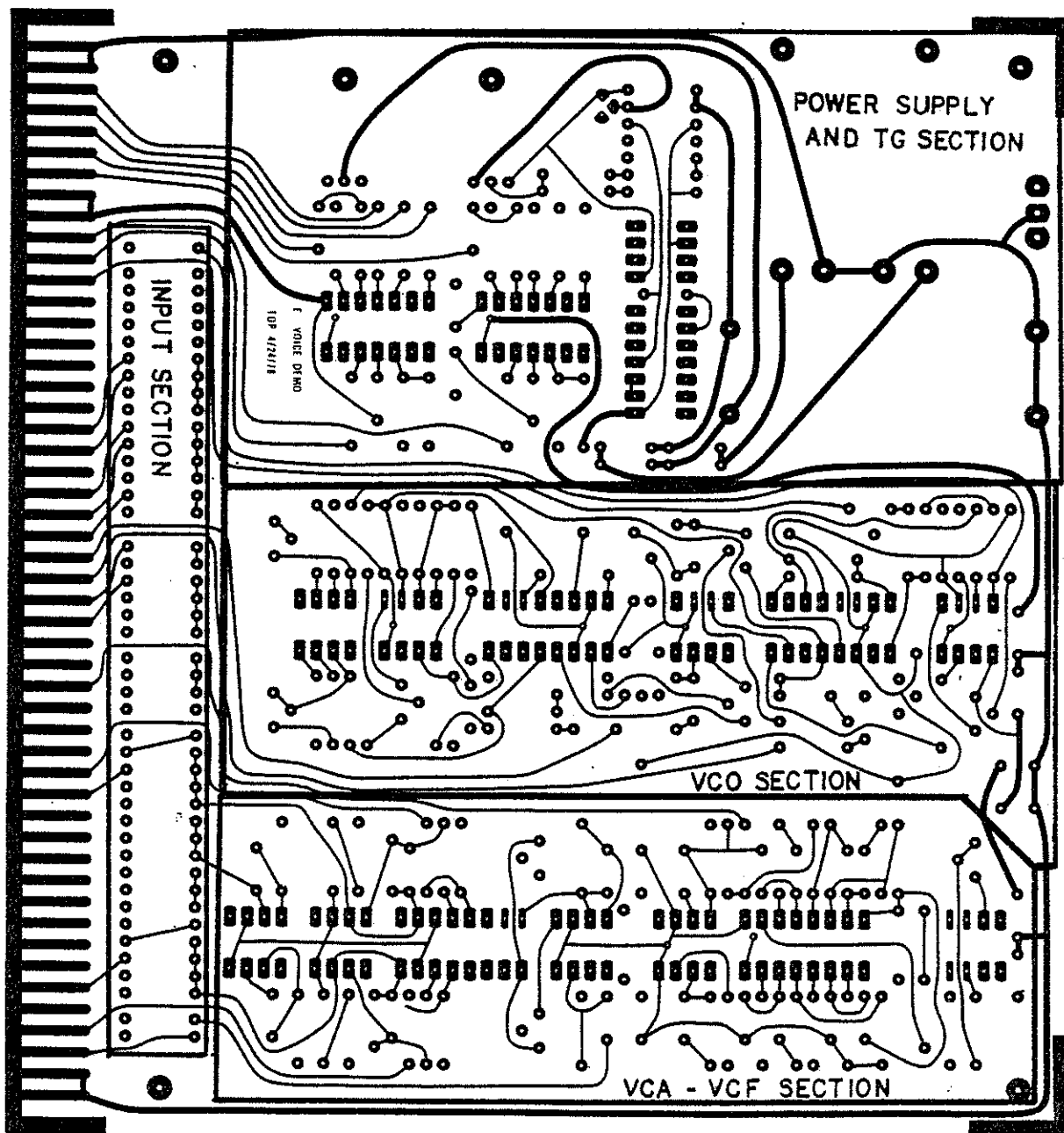

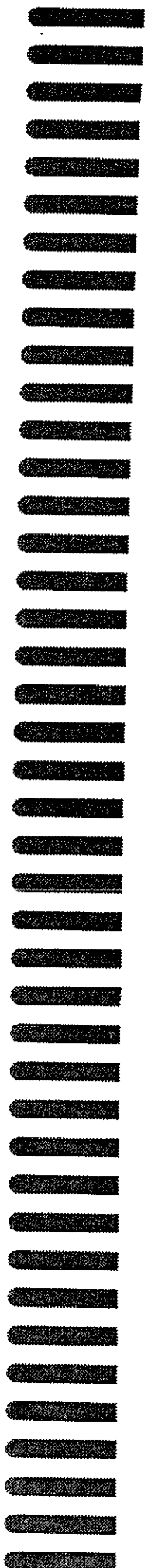
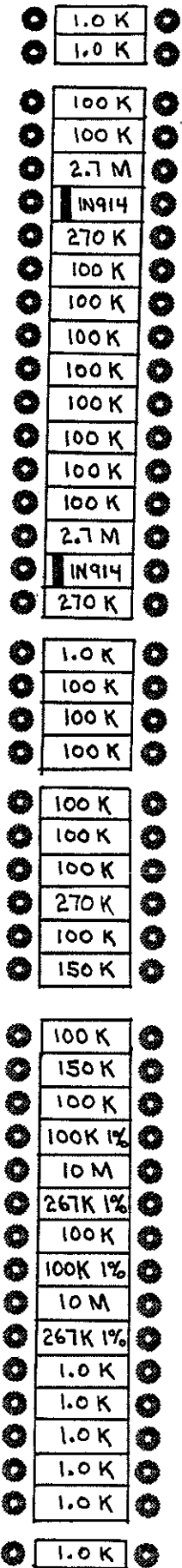

INPUT SECTION

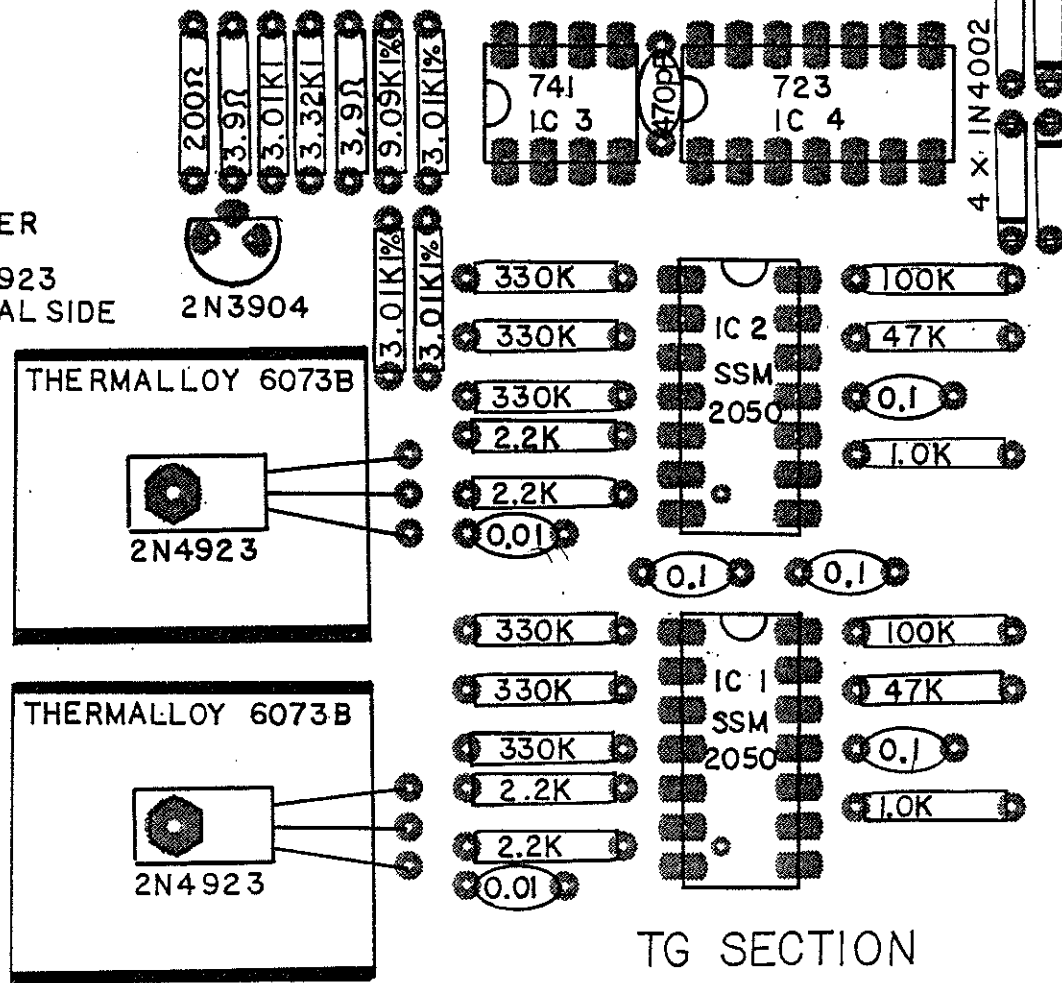
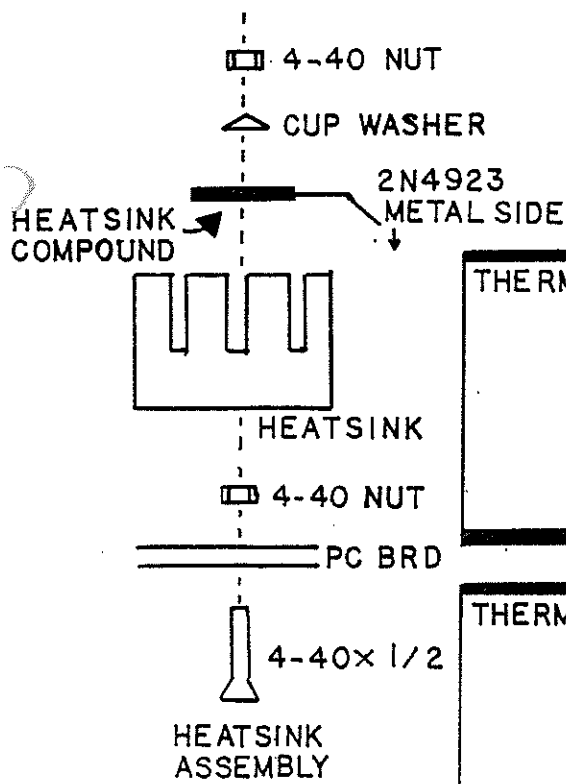
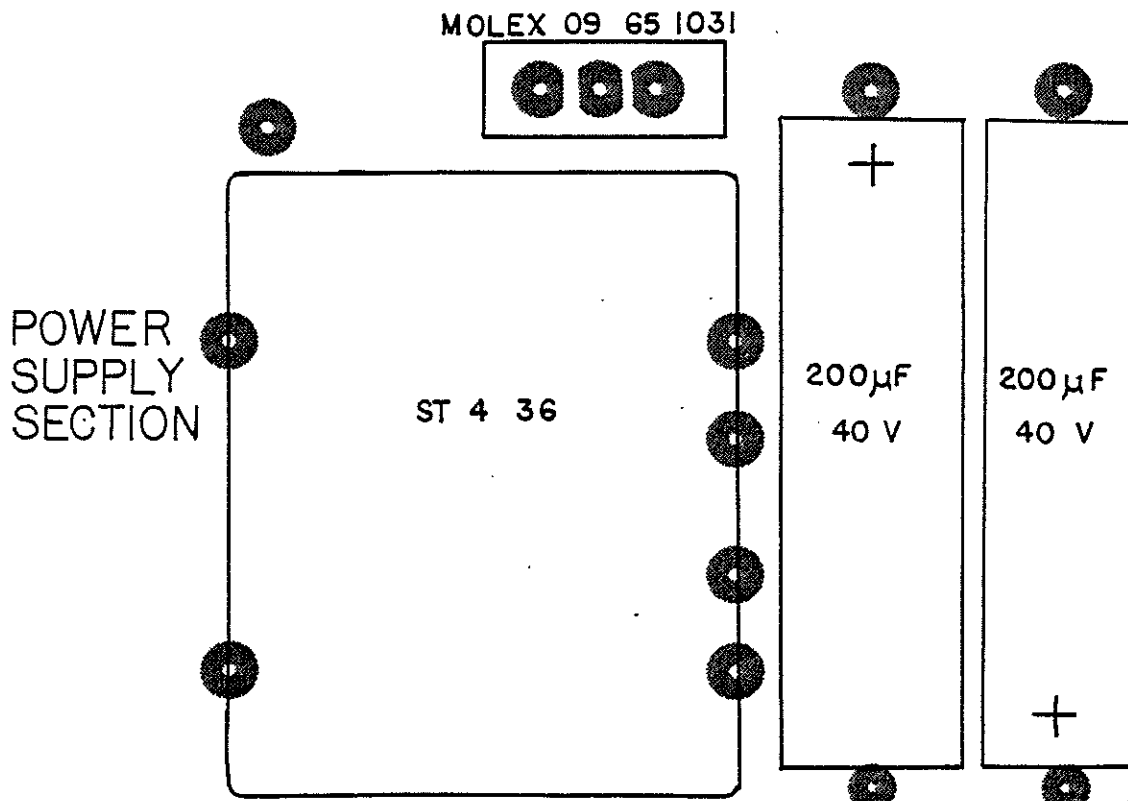

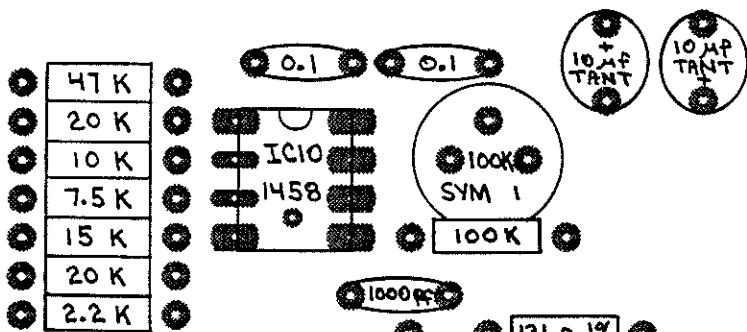

VCO 1
SECTION

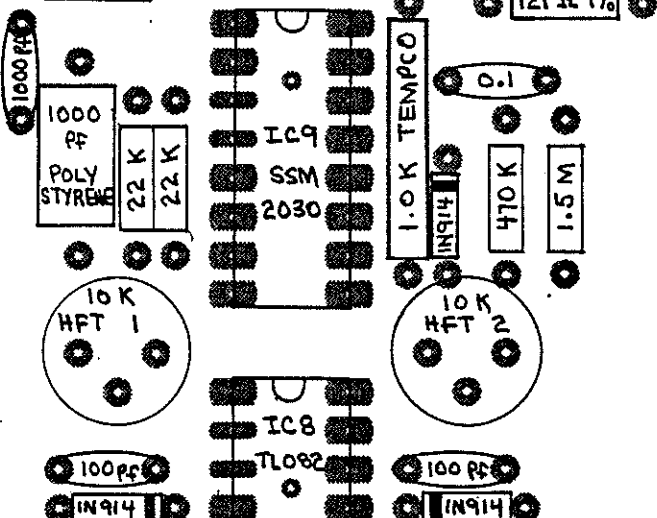

VCO 2
SECTION

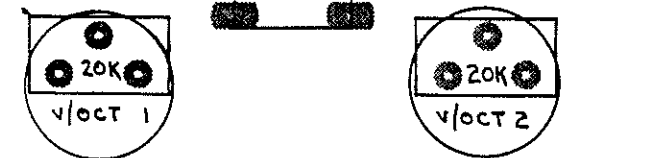
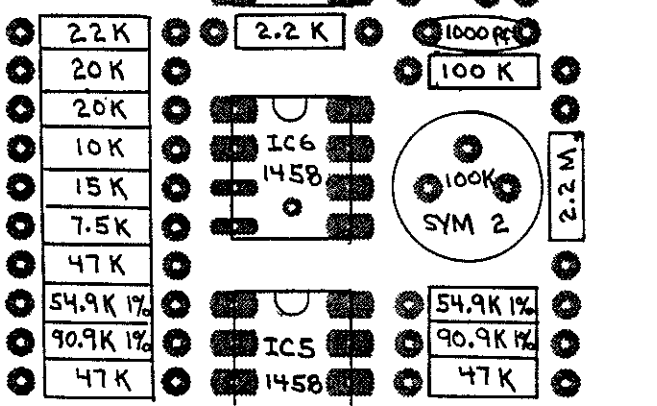
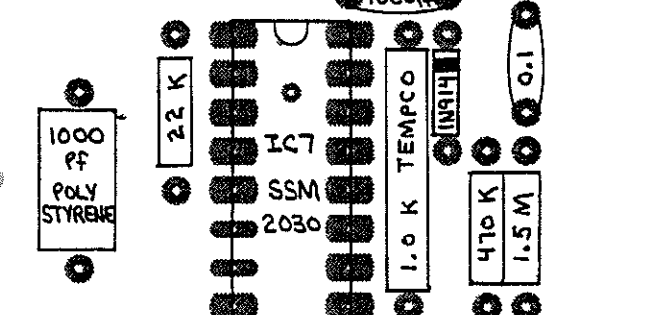

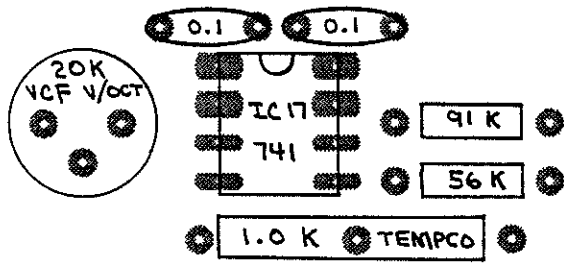

VCF SECTION

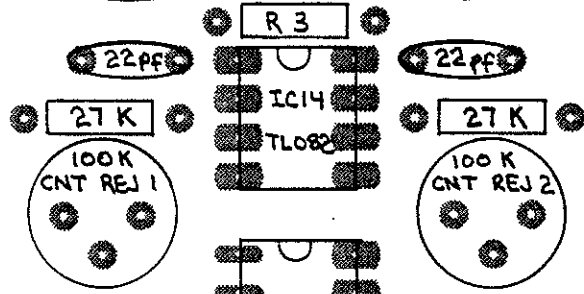
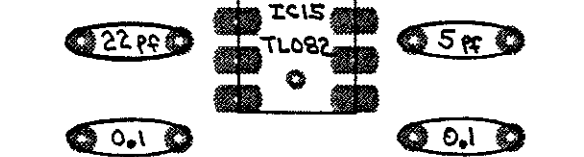
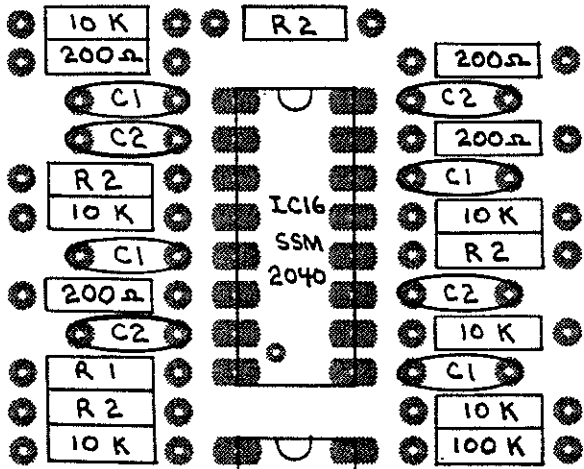

VCA SECTION

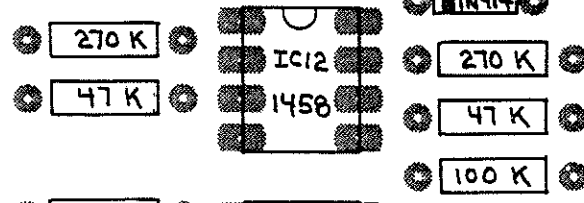
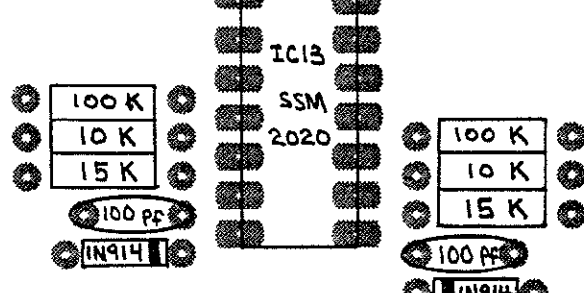

FILTER FUNCTION:	C1:	C2:	R1:	R2:	R3:
VCLPF	1000pf	—	10K	10K	—
VCHPF	—	2000pf	—	—	—
ALL PASS (PHASE SHIFT)	—	2000pf	—	10K	10K

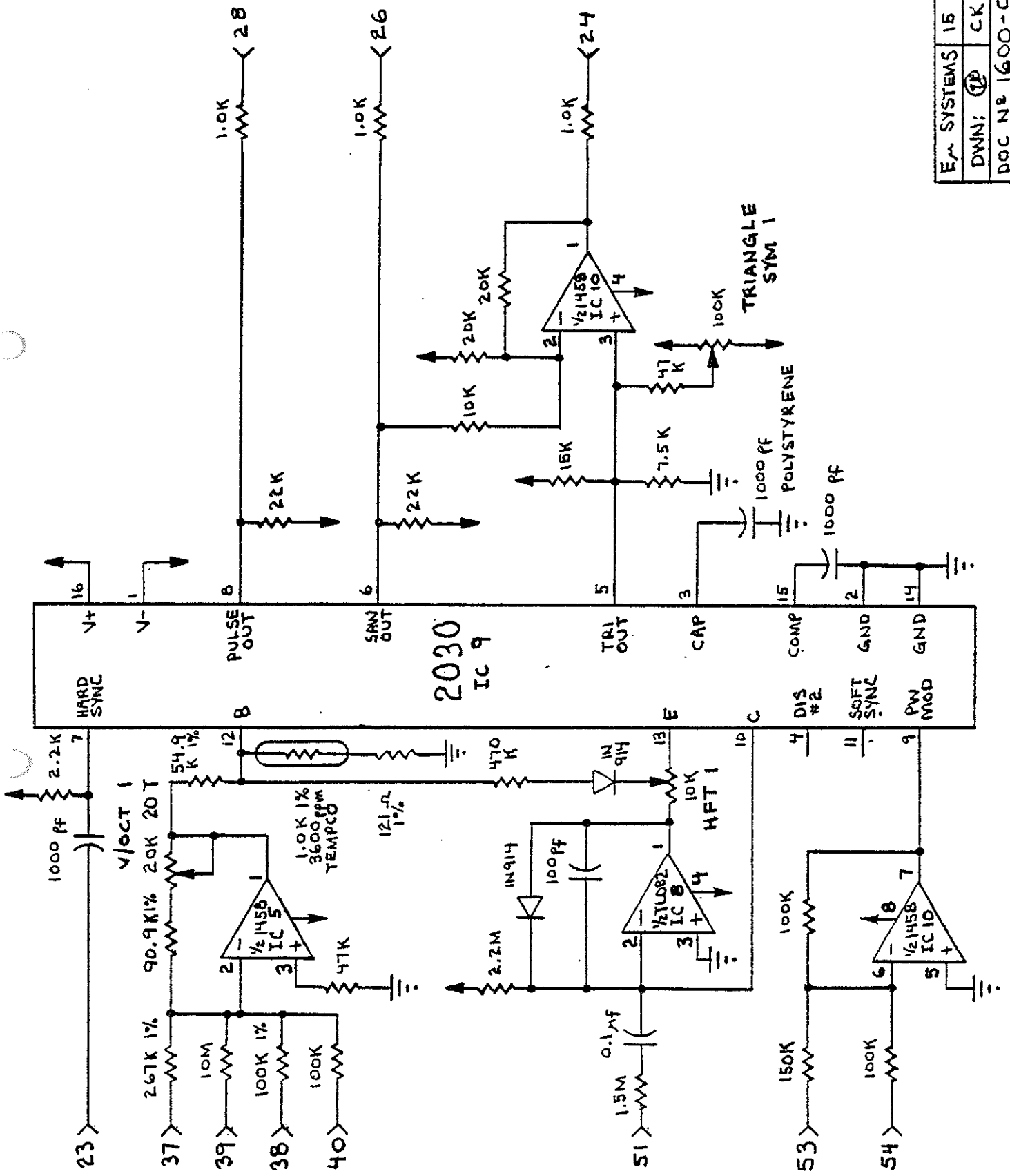

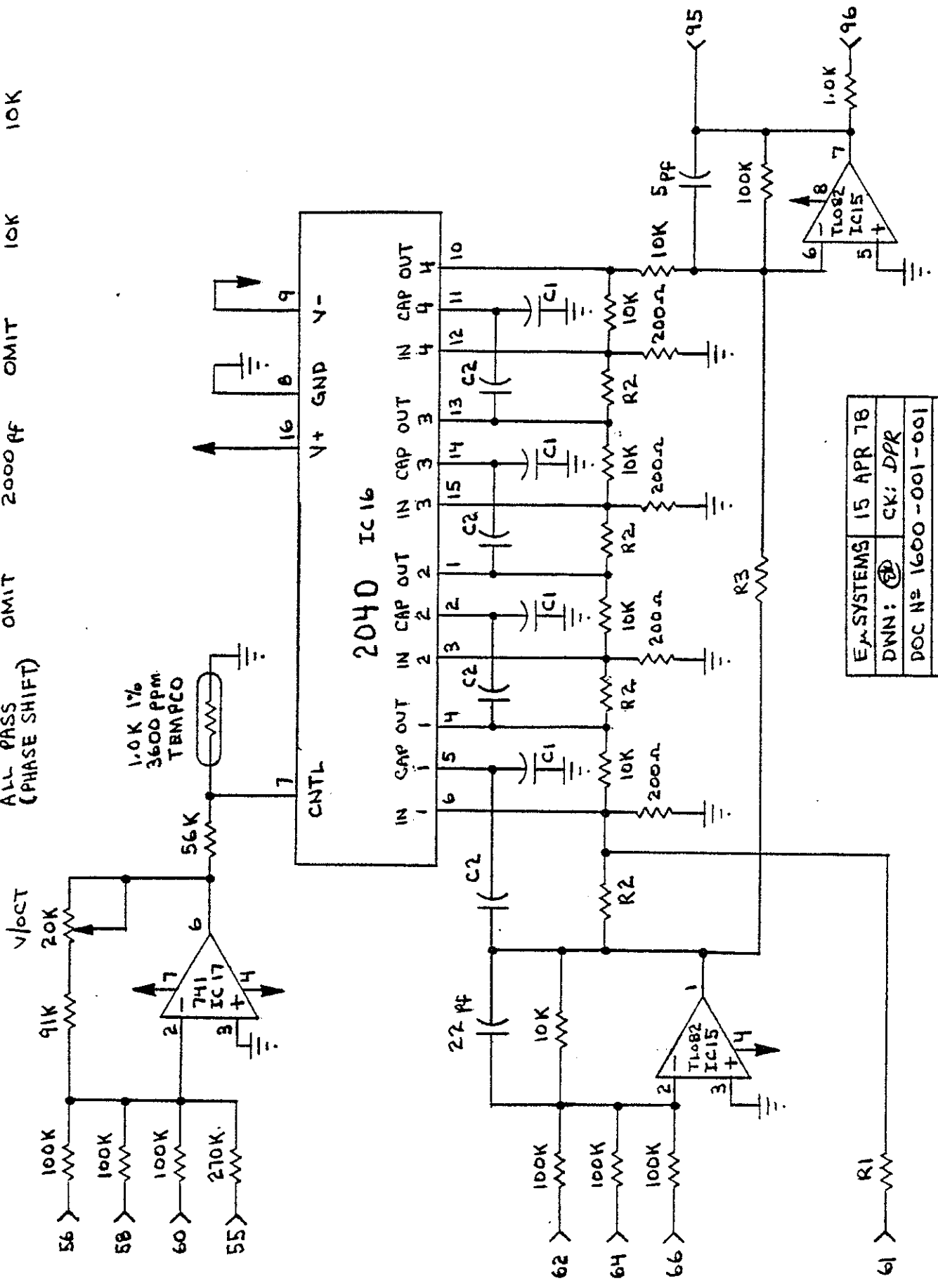

EA SYSTEMS	15 APR 78
DWIN: (P)	CK: DPR
DOC N°	1600-001-001
SCHEMATIC ~ EA VOICE	

FUNCTION:	C1:	C2:	R1:	R2:	R3:
VCLPF	1000PF	OMIT	10K	10K	OMIT
VCHPF	OMIT	2000PF	OMIT	OMIT	OMIT
ALL PASS (PHASE SHIFT)	OMIT	2000PF	OMIT	10K	10K

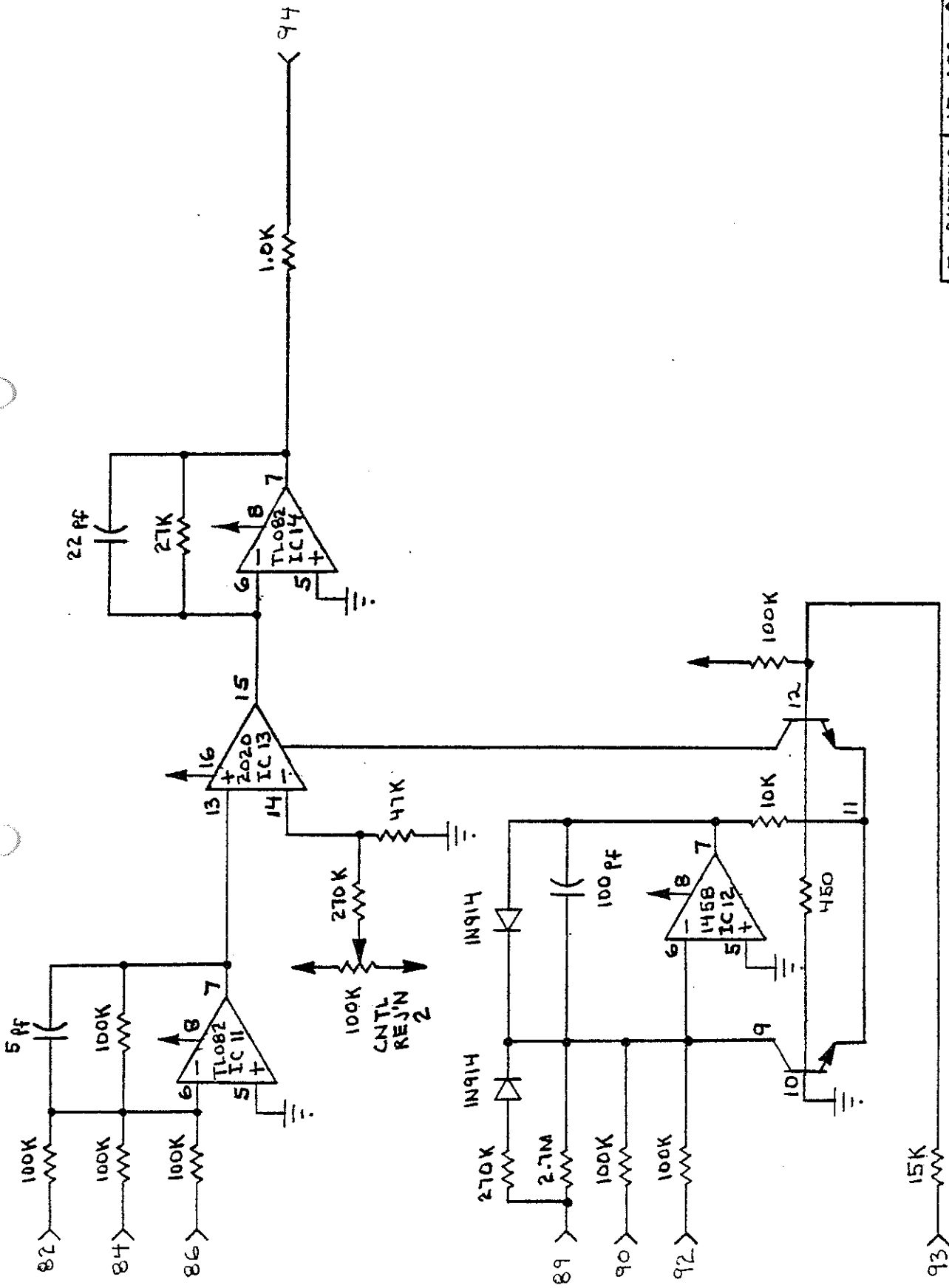

EM SYSTEMS	15 APR 78
DNN:	CK: DPR
DOC N# 1600-001-001	
SCHEMATIC ~ EM VOICE	
DEMO, VCLPF/HF FILTER	



EPA SYSTEMS	15 APR 78
DWN: 	CK: DPR
DOC N° 1600-001-001	
SCHEMATIC ~ EPA VOICE	
DEMO, VCA 2	

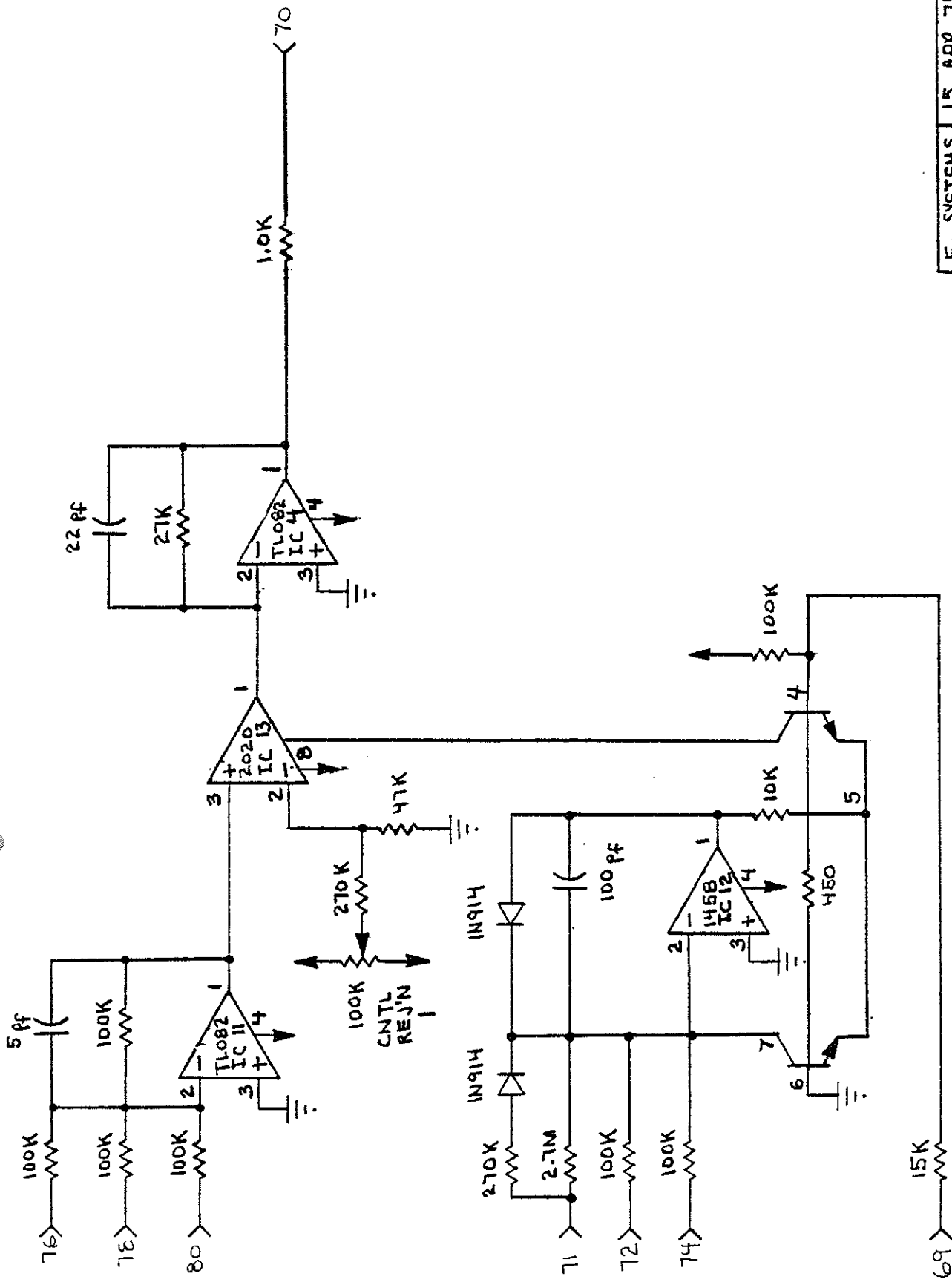

EA SYSTEMS	15 APR 78
DWN:	CK: DPR
DOC N° 1600-001-001	
SCHEMATIC ~ EA VOICE	
DEMO, VCA 1	

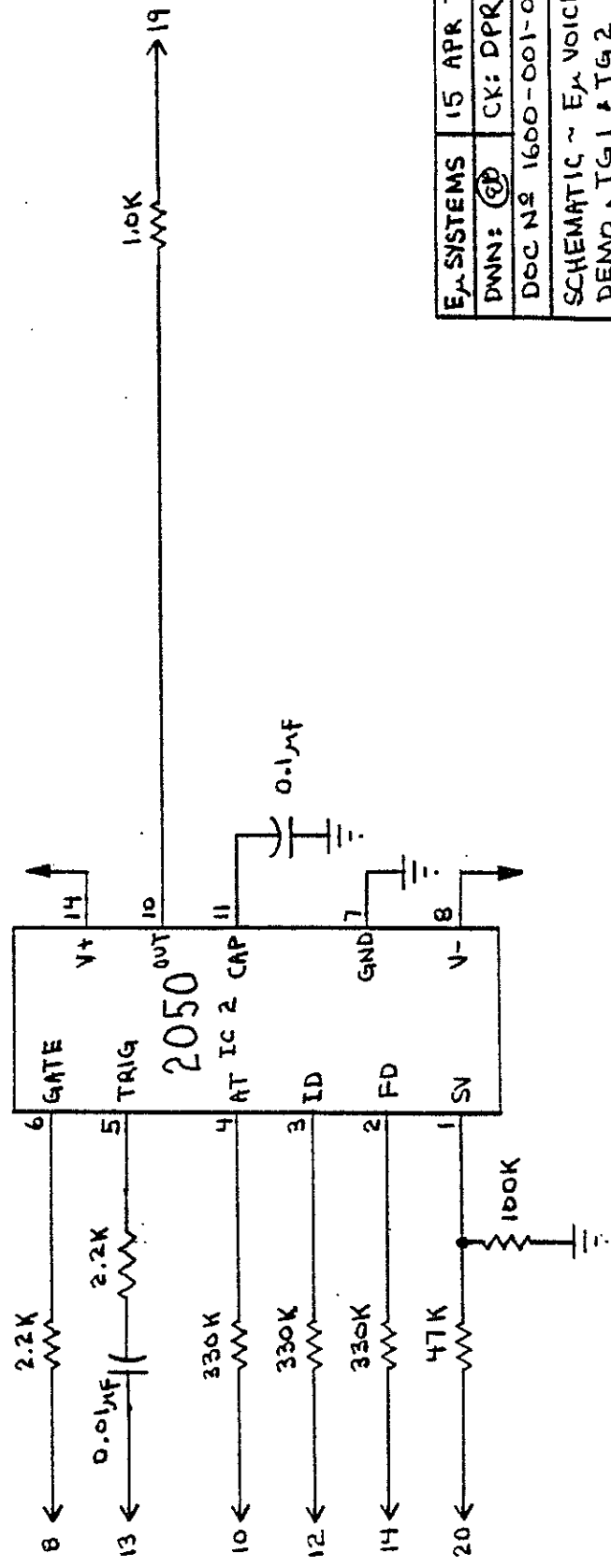
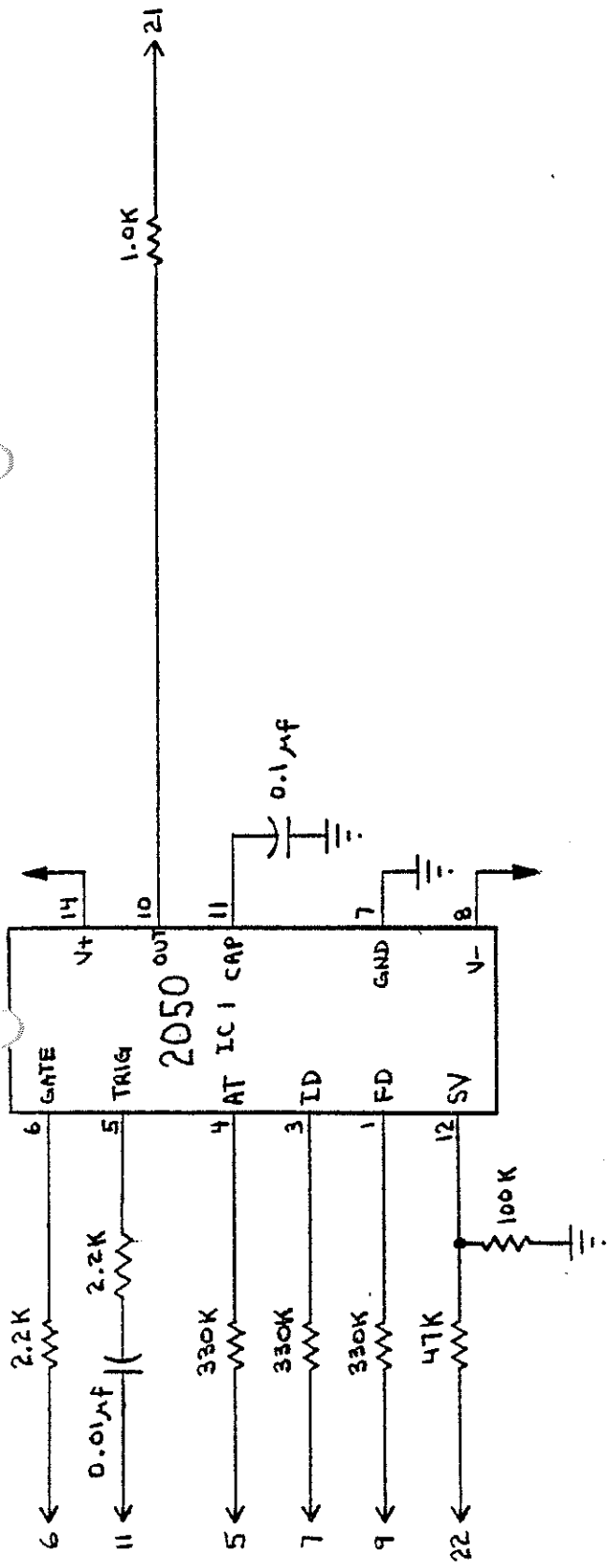

E _μ SYSTEMS	15 APR 78
DWNN: 	CK: DPR
DOC N ^o 1600-001-001	
SCHEMATIC ~ E _μ VOICE	
DEMO, TG1 & TG2	

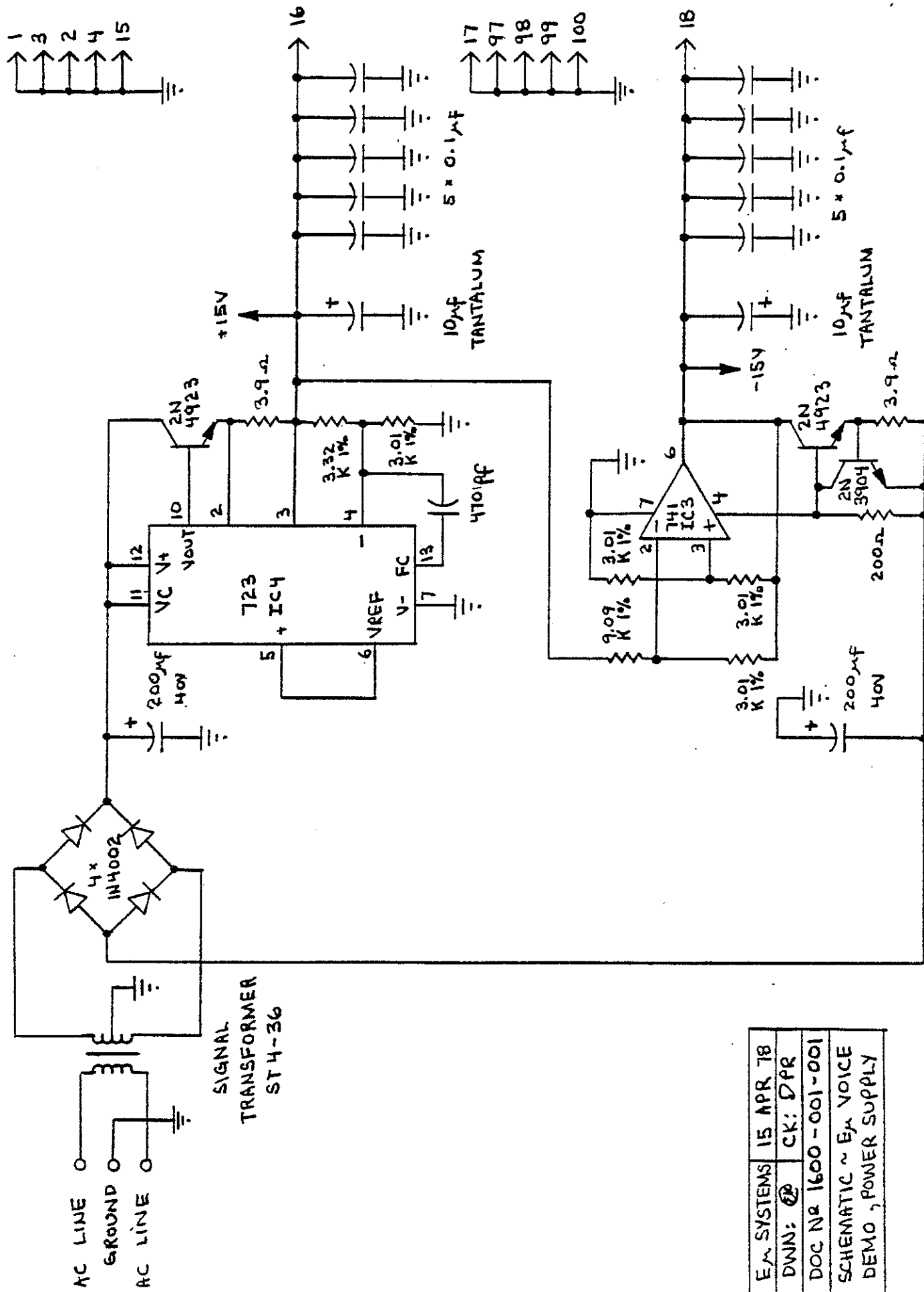

AC LINE
GROUND
AC LINE

SIGNAL
TRANSFORMER
ST 4-36

EM SYSTEMS	15 APR 78
DWNN:	CK: DPR
DOC No 1600-001-001	
SCHEMATIC ~ EM VOICE	
DEMO, POWER SUPPLY	

E-mu Systems Voice Demo Board - Pinouts

Pin #	Signal Name	Typical Connection
1-4	Ground	Panel Ground
5	TG1 Attack Input	TG1 Attack Pot
6	TG1 Gate Input	TG1 Gate Input Jack
7	TG1 Init Decay Input	TG1 Initial Decay Pot
8	TG2 Gate Input	TG2 Gate Input Jack
9	TG1 Final Decay Input	TG1 Final Decay Pot
10	TG2 Attack Input	TG2 Attack Pot
11	TG1 Trigger Input	TG1 Trigger Input Jack
12	TG2 Init Decay Input	TG2 Initial Decay Pot
13	TG2 Trigger Input	TG2 Trigger Input Jack
14	TG2 Final Decay Input	TG2 Final Decay Pot
15	Ground	Panel Ground
16	+15V	Panel +15 for Pots
17	Ground	Panel Ground
18	-15V	Panel -15V for Pots
19	TG2 Output	TG2 Output Jack
20	TG2 Sustain V Input	TG2 Sustain Voltage Pot
21	TG1 Output	TG1 Output Jack
22	TG1 Sustain V Input	TG1 Sustain Voltage Pot
23	VC01 Sync Input	VC01 Sync Input Jack
24	VC01 Triangle Output	VC01 Triangle Output Jack
26	VC01 Sawtooth Output	VC01 Sawtooth Output Jack
28	VC01 Pulse Output	VC01 Pulse Output Jack
30	VC02 Pulse Output	VC02 Pulse Output Jack
32	VC02 Sawtooth Output	VC02 Sawtooth Output Jack
34	VC02 Triangle Output	VC02 Triangle Output Jack
37	VC01 Init Freq Coarse	VC01 Initial Freq Coarse Pot
38	VC01 Keyboard Input	VC01 Keyboard Input Jack
39	VC01 Init Freq Fine	VC01 Initial Freq Fine Pot
40	VC01 Freq Mod Input	VC01 Frequency Modulation Input Attenuator
43	VC02 Init Freq Coarse	VC02 Initial Freq Coarse Pot
44	VC02 Keyboard Input	VC02 Keyboard Input Jack
45	VC02 Init Freq Fine	VC02 Initial Freq Fine Pot
46	VC02 Freq Mod Input	VC02 Frequency Modulation Input Attenuator
47	VC02 Pulse Width Cntl	VC02 Pulse Width Pot
48	VC02 Pulse Width Input	VC02 Pulse Width Mod Input Attenuator
49	VC02 Linear FM Input	VC02 Linear FM Input Attenuator
51	VC01 Linear FM Input	VC01 Linear FM Input Attenuator
52	VC02 Sync Input	VC02 Sync Input Jack
53	VC01 Pulse Width Cntl	VC02 Pulse Width Pot
54	VC01 Pulse Width Input	VC01 Pulse Width Mod Input Attenuator
55	VCF Initial Freq Input	VCF Initial Frequency Pot
56,58,60	VCF Freq Cntl Inputs	VCF Freq Cntl Input Attenuators
61	VCF Resonance Input	VCF Resonance Control
62,64,66	VCF Signal Inputs	VCF Signal Input Attenuators
69	VCA1 Exp'l Cntl Input	VCA1 Exp'l Gain Cntl Input Attenuator
70	VCA1 Output	VCA1 Output Jack
71	VCA1 Init Gain Input	VCA1 Initial Gain Pot
72,74	VCA1 Gain Cntl Inputs	VCA1 Gain Control Input Attenuators
76,78,80	VCA1 Signal Inputs	VCA1 Signal Input Attenuators
82,84,86	VCA2 Signal Inputs	VCA2 Signal Input Attenuators
89	VCA2 Init Gain Input	VCA2 Initial Gain Pot
90,92	VCA2 Gain Cntl Inputs	VCA2 Gain Control Input Attenuators
93	VCA2 Exp'l Cntl Input	VCA2 Exp'l Gain Cntl Input Attenuator
94	VCA2 Output	VCA2 Output Jack
95	VCF Resonance Output	VCF Resonance Control
96	VCF Output	VCF Output Jack
97-100	Ground	Panel Ground

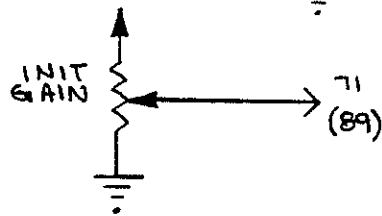
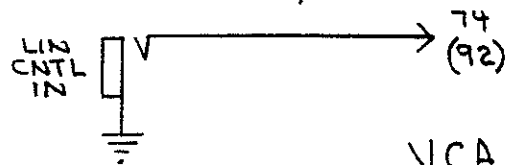
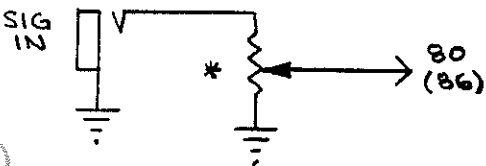
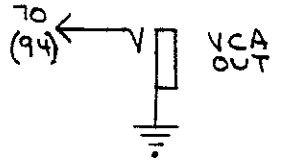
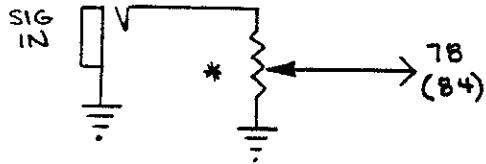
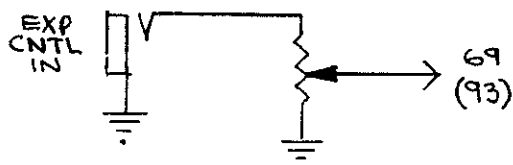
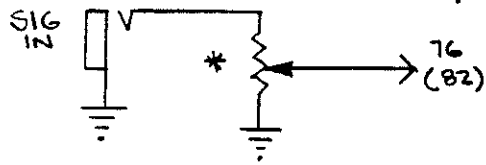

VCA
(x2)

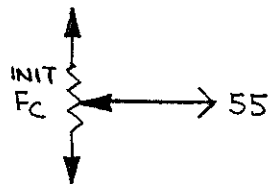
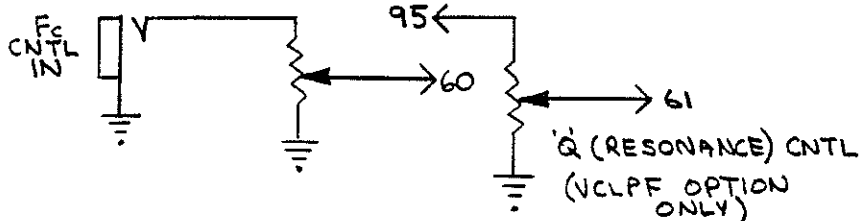
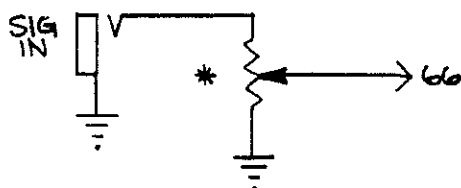
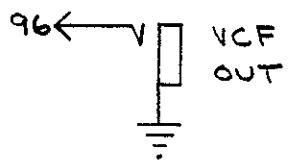
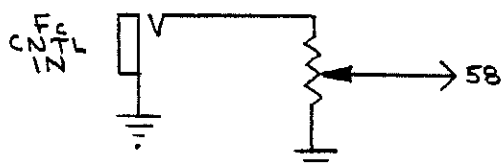
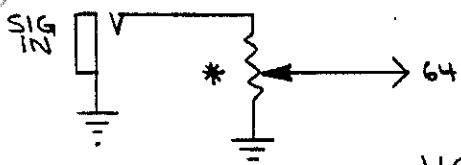
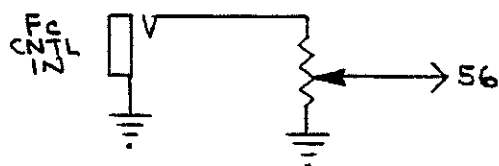
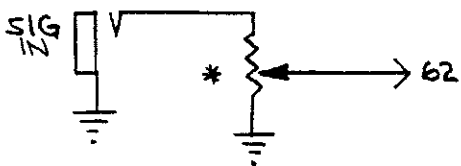

VCF (x1)

ALL POTS 100K
 LINEAR ALWAYS OK
 * = LOG PREFERRED
 (n) = 2nd SECTION REF.

E _μ SYSTEMS	15 MAY 78
DWN: (80)	CK: m
DOC N ^o 1600-001-001	
SCHEMATIC ~ E _μ VOICE DEMO: TYP. FRONT PANEL	

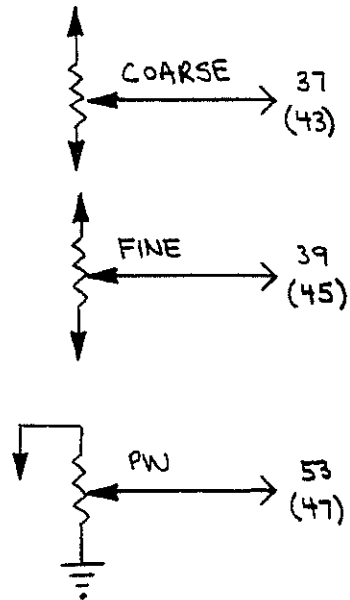
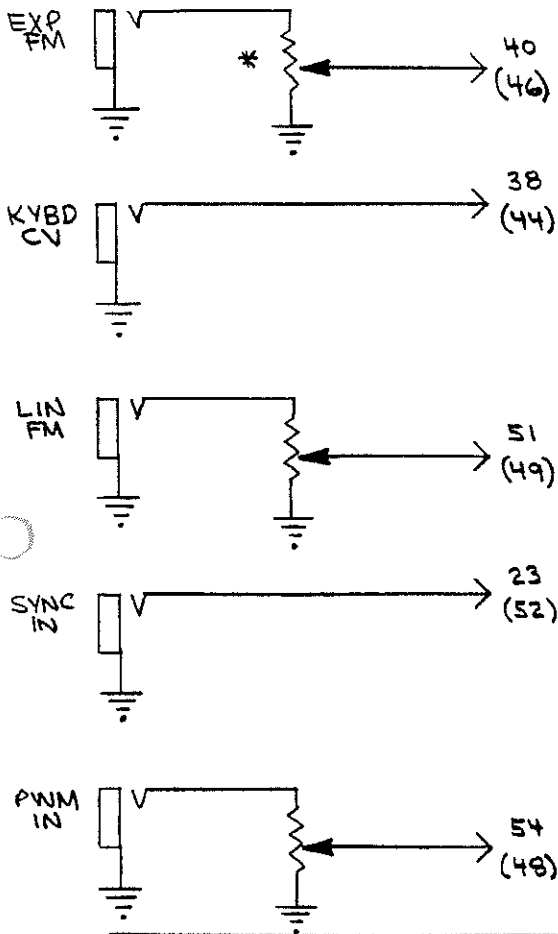

VCO
(x 2)

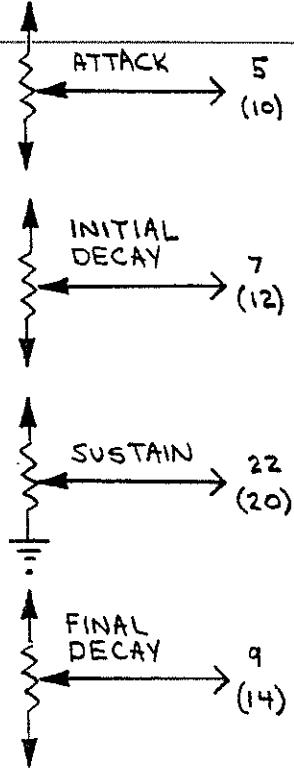
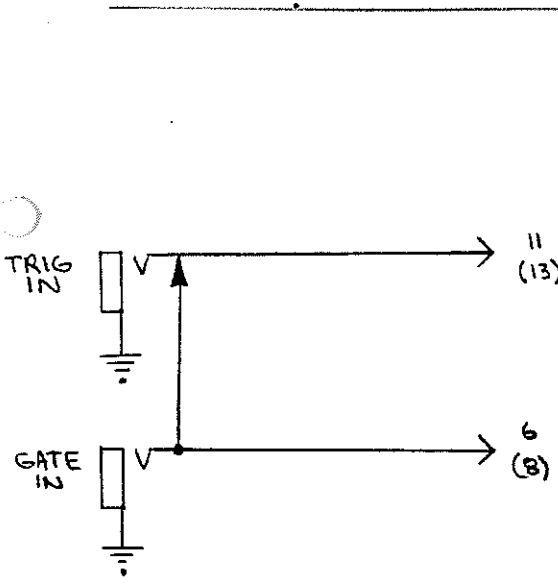
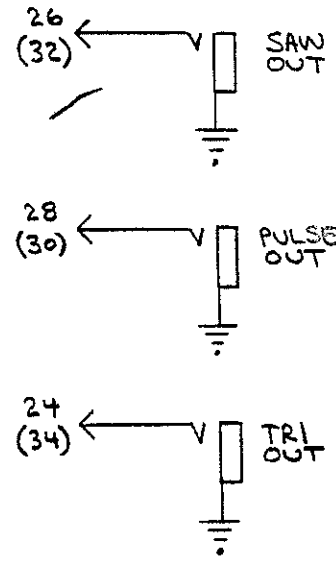

TG
(x 2)

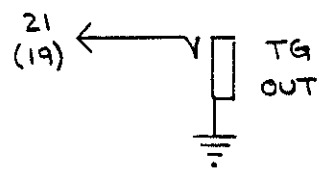

ALL POTS 100K
 LINEAR ALWAYS OK
 * = LOG PREFERRED
 (n) = 2nd SECTION REF.

E μ SYSTEMS	15 MAY 78
DWN: $\text{\textcircled{E}}$	CK: \mathcal{M}
DOC N $\text{\textcircled{E}}$ 1600 - 001 - 001	
SCHEMATIC ~ E μ VOICE	
DEMO: TYP. FRONT PANEL	



E-MU SYSTEMS VOICE DEMO - TRIM PROCEDURE

OCILLATOR TRIMS (2 each):

SYM: Monitor triangle output of VCO with 'scope or ear. With 'scope, adjust for minimal glitch on triangle waveform. With ear, adjust for minimal buzz; this is best done at lower frequencies. The waveform will never be quite perfect.

V/OCT: Monitor sawtooth output of VCO. Adjust for precisely 1 octave shift from 100 to 200 Hz for a 1 volt change at the keyboard input. This is usually best done by ear, but a good 'scope can be used. The 1 volt source is usually the system keyboard if one is used, but any precise 1 volt reference will do. The most important thing is that the oscillators track.

HFT: Do this after V/OCT. This trim optimizes the VCO tracking at high frequencies. While monitoring the sawtooth output of the VCO, adjust for precisely 1 octave shift from 2000 to 4000 Hz for a 1 volt change at the keyboard input. You may wish to re-trim the V/OCT trim after you first adjust the HFT.

FILTER:

V/OCT: With the lowpass configuration, turn up the "Q" until the filter oscillates. Adjust so that a 1 volt change on a frequency control input results in a 1 octave shift in frequency from 250 to 500 Hz. With highpass or allpass configuration the trim is much more difficult. It is usually satisfactory to just center the trimmer, but you may either adjust the trimmer for precisely 18.02 mV change at pin 7 of IC 16 at room temperature for 1 volt change on a frequency control input, or adjust such that the output waveform from a VCO tracking the filter stays constant.

VCA (2 each):

CNT R: Connect a 1 KHz triangle waveform to a gain control input, and monitor the output of the VCA. Adjust for minimal audio output. The signal inputs to the VCA must be open.